



Visit our homepage
for additional support
parker.com/pmde

MSG30-8202-INST/EU

Installation and start-up information Hydraulic Pumps Series F3/F4

Effective: May, 2022

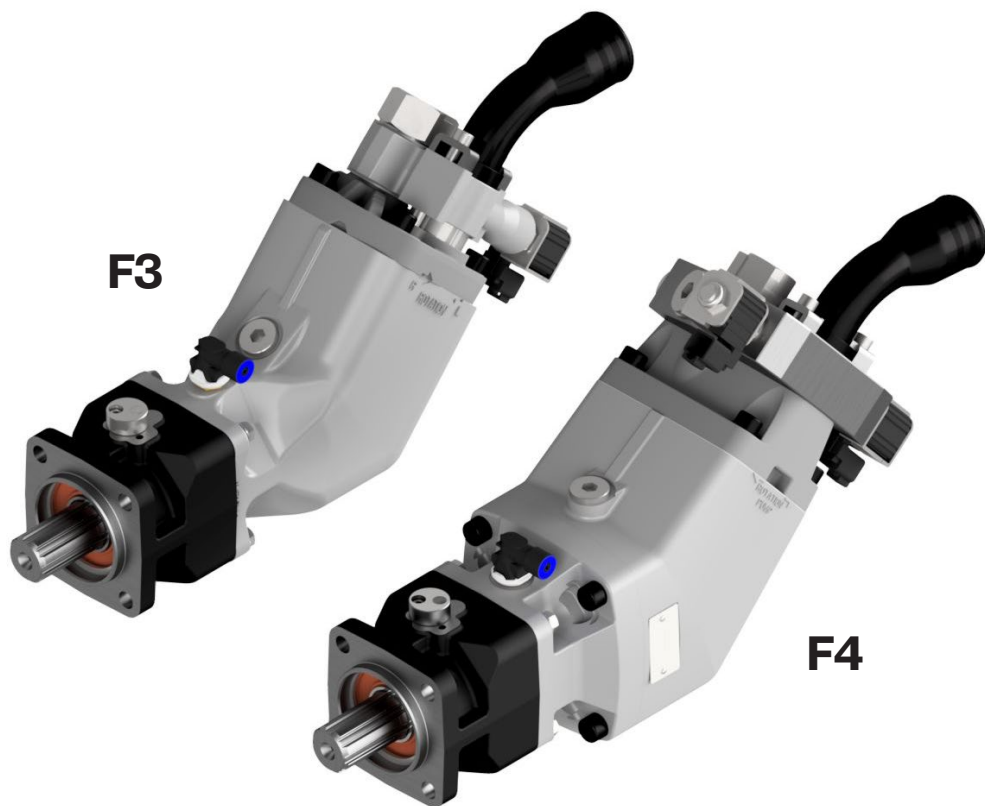

ENGINEERING YOUR SUCCESS.

Important installation information

Series F3 and F4 (fixed displacement)

Wichtige Installationsinformationen

Serie F3 and F4 (konstantes Verdrängungsvolumen)

Informations importantes pour l'installation

Séries F3 and F4 (cylindrées fixes)

| Content | Page | Inhalt | Seite | Contenu | Page |
|--|------|--|-------|---|------|
| 1) Use the correct suction fitting | 3 | 1) Verwendung der richtigen Sauganschlüsse | 3 | 1) Choix du raccord d'aspiration..... | 3 |
| 2) Suction fittings | 4 | 2) Sauganschlüsse | 4 | 2) Raccord d'aspiration | 4 |
| 3) Port installation notes | 5 | 3) Sauganschlussmontage... .. | 5 | 3) Orifices..... | 5 |
| 4) Block diagram | 6 | 4) Blockdiagramm | 7 | 4) Bloc diagramme | 8 |
| 5) Before start-up..... | 9 | 5) Inbetriebnahme..... | 9 | 5) Avant le démarrage..... | 9 |
| 6) If any oil should come out of the indication-hole on the pump;..... | 10 | 6) Falls Öl aus der Anzeigeöffnung der Pumpe austreten sollte: | 10 | 6) En cas de fuite d'huile par l'orifice indicateur de la pompe : | 10 |
| 7) Fluids | 10 | 7) Hydraulikflüssigkeiten | 10 | 7) Fluides..... | 10 |

| | | |
|---|---|--|
| Important installation info. Series F3/F4 (fixed displacement pumps) | Wichtige Installationsinfo. Serie F3/F4 (konst. Verdrängungsvolumen) | Informations importantes pour l'installation Séries F3/F4 (cylindrées fixes) |
|---|---|--|

1) Use the correct size suction fitting

1) Verwendung der richtigen Sauganschlüsse

1) Choix du raccord d'aspiration

| Line type | Flow velocity [m/s] |
|--------------------|---------------------------------|
| Anschlussstyp | Durchflussgeschwindigkeit [m/s] |
| Type de tuyau | Vitesse d'écoulement [m/s] |
| Inlet (suction) | max 1.0 |
| Sauganschluss | |
| Tuyau d'aspiration | |
| Outlet (pressure) | max. 5.0 |
| Druckanschluss | |
| Tuyau de pression | |

| Flow | Flow velocity [m/s] at selected line size [mm/inches] | | |
|---------------|---|---------------|-----------|
| Fördermenge | Durchflussgeschwindigkeit [m/s] bei den angegebenen Leitungsabmessungen [mm/zoll] | | |
| Débit d'huile | Vitesse d'écoulement [m/s] pour un diamètre donné [mm/inch] | | |
| [l/min] | C 50 / 2" | C 63 / 2 1/2" | C 75 / 3" |
| 65 | 0.6 | 0.3 | 0.3 |
| 115 | 1.0 | 0.6 | 0.4 |
| 185 | 1.6 | 1.0 | 0.7 |
| 265 | 2.3 | 1.4 | 1.0 |

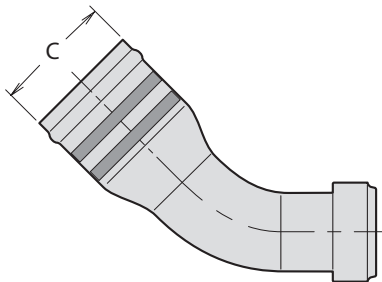

2) Suction fittings

A 'suction fitting' consists of a straight, 45° or 90° suction fitting, clamps, cap screws and O-ring.

2) Sauganschlüsse

Ein "Sauganschluss" besteht aus einem geraden, 45°- oder 90°- Sauganschluss, Klemmen, Kopfschrauben und einem O-Ring.

2) Raccord d'aspiration

Un raccord d'aspiration est constitué : d'un raccord coudé à 45° ou 90°, de brides, des vis et d'un joint O-ring.

'Straight' suction fittings

| Part no. | A mm | B mm | C dia. mm (in.) |
|------------------------|------|------|-----------------|
| 3780636 ¹⁾ | 16 | 136 | 50 (2") |
| 378 0637 ¹⁾ | 25 | 145 | 63 (2 1/2") |
| 378 3523 ¹⁾ | 32 | 174 | 75 (3") |

'Straight' fitting

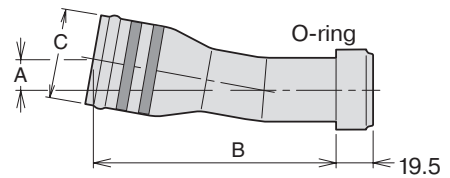

45° suction fittings

| Part no. | A mm | B mm | C dia. mm (in.) |
|------------------------|------|------|-----------------|
| 3780364 ¹⁾ | 67 | 110 | 50 (2") |
| 378 0634 ¹⁾ | 75 | 117 | 63 (2 1/2") |
| 378 3367 ¹⁾ | 95 | 138 | 75 (3") |

45° fitting

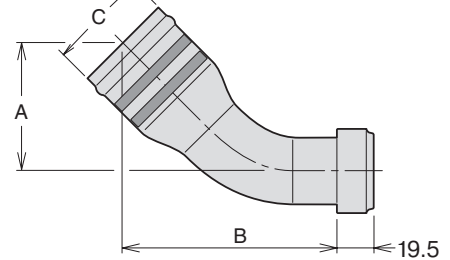

90° suction fittings

| Part no. | A mm | B mm | C dia. mm (in.) |
|------------------------|------|------|-----------------|
| 3780979 ¹⁾ | 135 | 83 | 50 (2") |
| 378 1980 ¹⁾ | 147 | 83 | 63 (2 1/2") |
| 378 8690 ¹⁾ | 185 | 83 | 75 (3") |

90° fitting

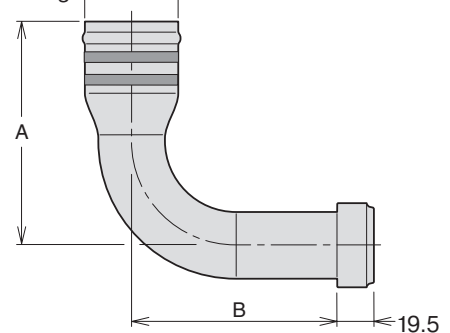

- 1) (3 clamps and 3 screws)
 (3 Klammer und 3 Schraube)
 (3 agrafes et 3 vis)

| Important installation info. Series F3/F4 (fixed displacement pumps) | Wichtige Installationsinfo. Serie F3/F4 (konst. Verdrängungsvolumen) | Informations importantes pour l'installation Séries F3/F4 (cylindrées fixes) |
|---|---|--|
|---|---|--|

3) Port installation notes

a) BPV suction fittings and screw torque

3) Sauganschlussmontage

a) BPV-Sauganschlussbefestigung und Schraubendrehmoment

3) Orifices

a) Raccords d'aspiration BPV et couple de vis

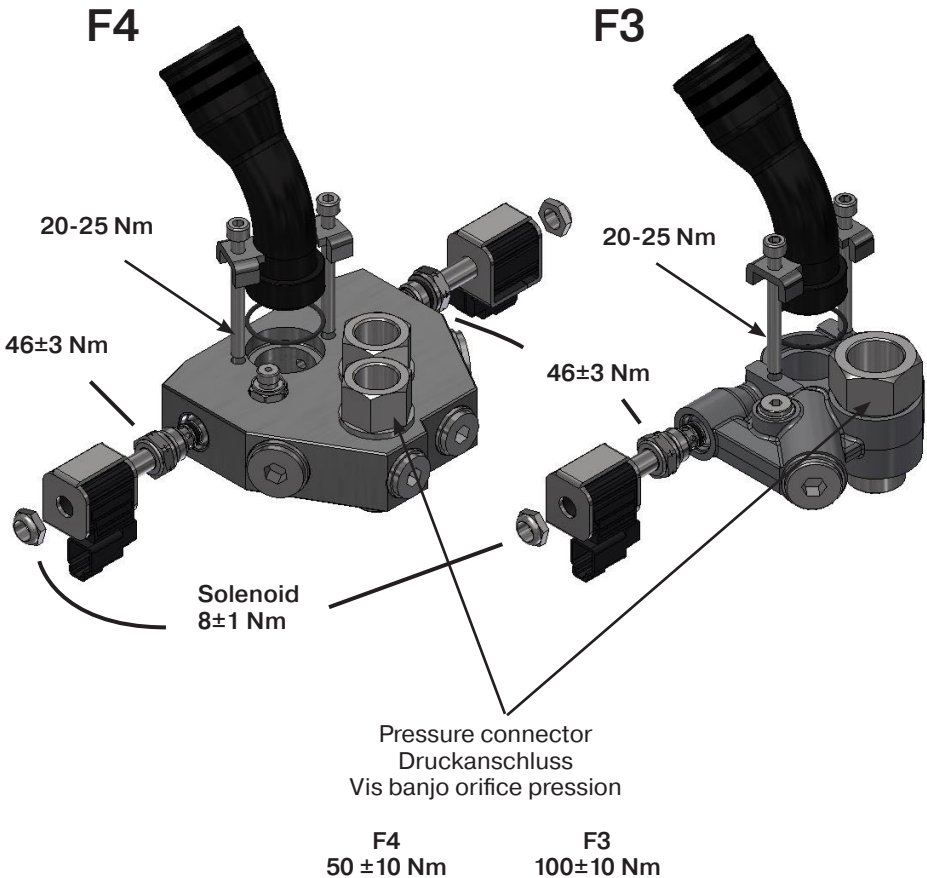

4) Block diagram engaging the F3/F4 pump

UK

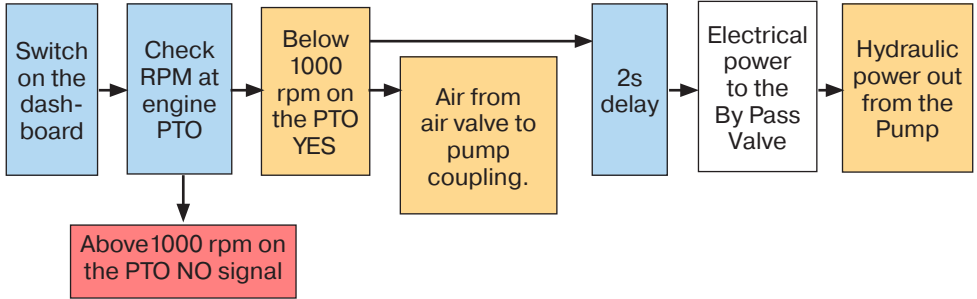

Product Demand

- Max pump shaft speed before the F3/F4 can be engaged is 1000 rpm. (verify engine PTO speed)
 - Air pressure > 5 bar before the clutch can start to engage the pump
- * For electrical diagram, contact Parker Hannifin
 * Check the bending torque limit on the PTO mount.
 F3 - Bending torque 33Nm
 F4 - Bending torque 60Nm

Interface

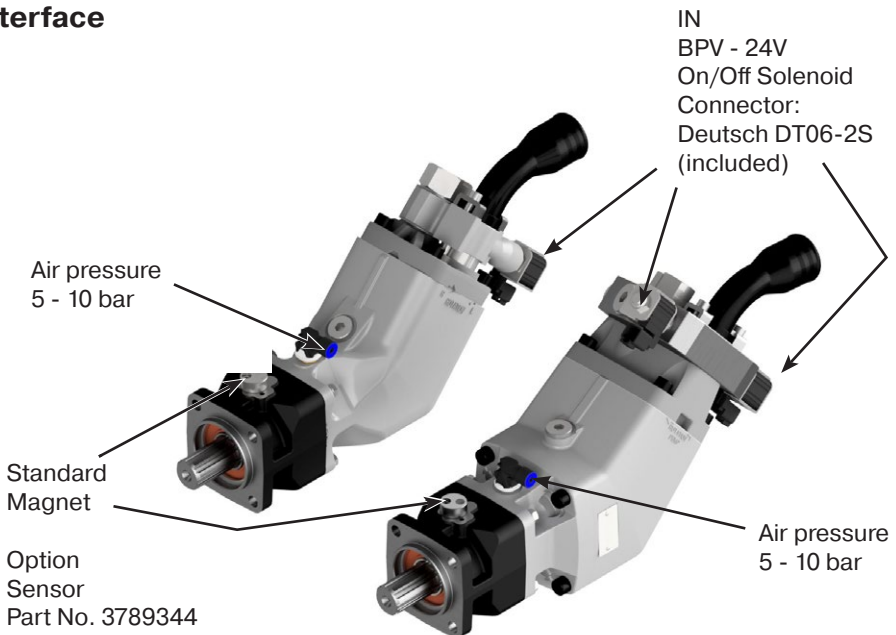

4) Blockdiagramm und Produkthanforderung F3/F4 Pumpe

DE

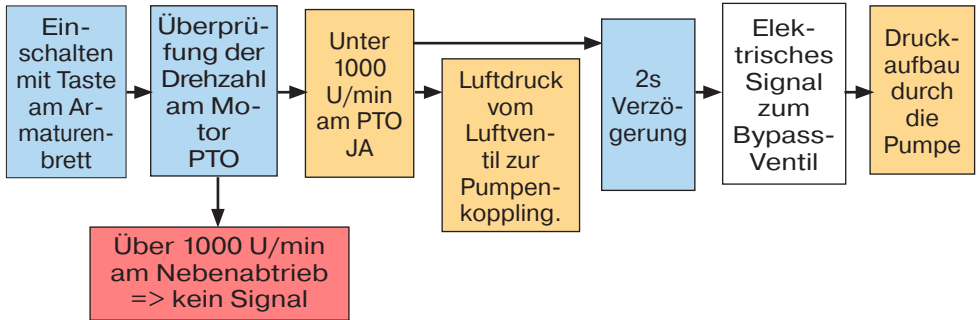

Produkthanforderung

- Die maximale Zuschaltdrehzahl, bevor die F3/F4 Pumpe aktiviert werden kann, beträgt 1000 U/min. (PTO-Drehzahl prüfen)
- Luftdruck > 5 bar für die Kopplung
- * Für Schaltpläne wenden Sie sich bitte an Parker Hannifin
- * Überprüfen Sie die Biegedrehmomentgrenze an der Zapfwellenhalterung.
 F3 - Biegemoment 33 Nm
 F4 - Biegemoment 60 Nm

Elektrische Anschlüsse

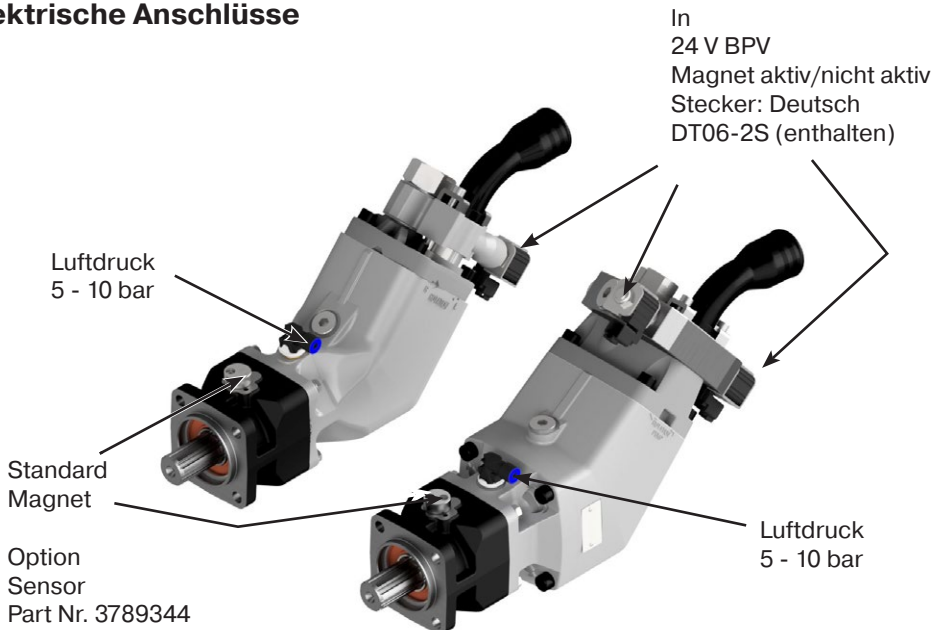

4) Process pour embrayer la pompe F3/F4

FR

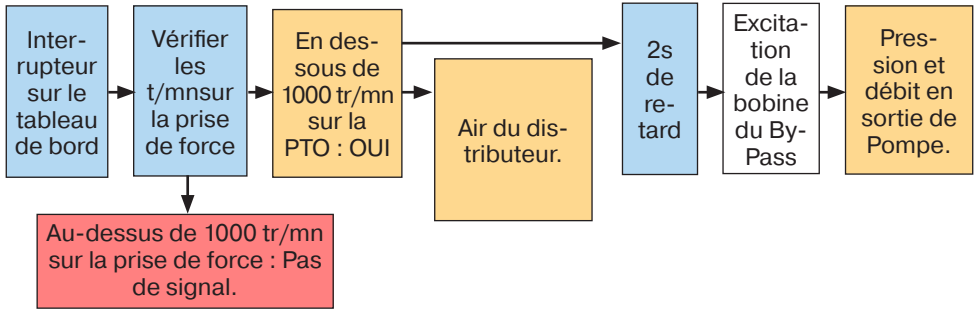

Préconisation avant utilisation

- La vitesse de démarrage maximale avant que la pompe F3/F4 puisse être activée est de 1 000 tr/min. (vérifier la vitesse de prise de force)
- La pression d'air disponible sur le camion doit être > 5 bars
- * Pour le schéma électrique, contactez Parker Hannifin
- * Vérifiez la limite de couple de flexion sur le support de prise de force.
F3 - couple de flexion 33Nm
F4 - couple de flexion 60Nm

Interfaces

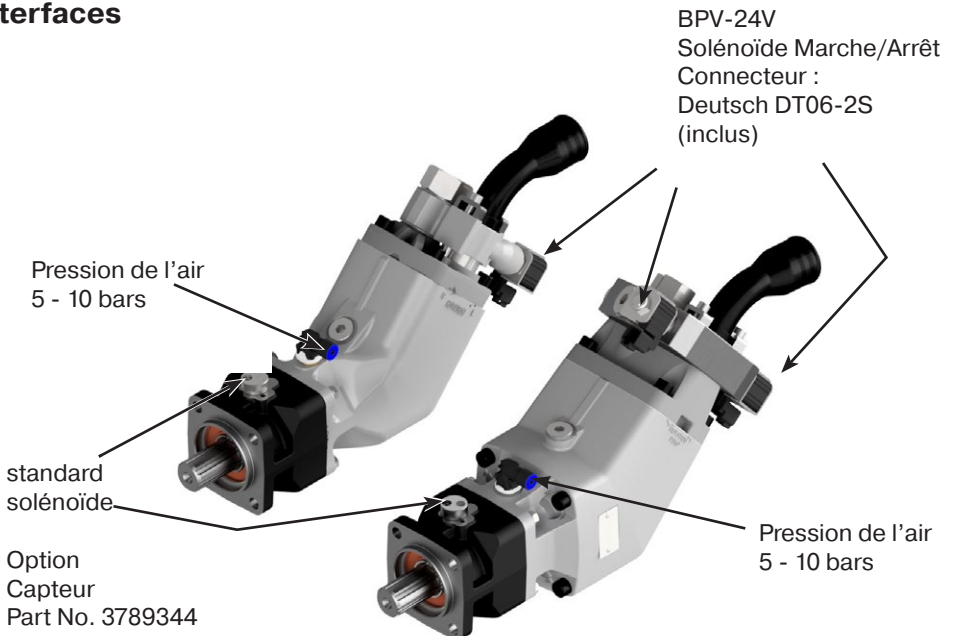

Important installation info.
Series F3/F4
(fixed displacement pumps)

Wichtige Installationsinfo.
Serie F3/F4
(konst. Verdrängungsvolumen)

Informations importantes pour l'installation
Séries F3/F4 (cylindrées fixes)

5) Before start-up

- Make sure the entire hydraulic system is clean before filling it with a recommended hydraulic fluid.
- Always fill the pump (and the entire hydraulic system) with a recommended oil before start-up.
- Fill the pump to at least 50 % (as the internal leakage does not provide sufficient lubrication at start-up) with oil by either:
 - a) Adding oil directly to the pump, or
 - b) Adding oil from the tank:
- Open the shut-off valve between tank and pump (if applicable)
- Open the pump drain plug; wait until oil pours out
- Tighten the drain plug.

5) Inbetriebnahme

- Stellen Sie sicher, dass das gesamte Hydrauliksystem sauber ist, bevor Sie es mit einer empfohlenen Hydraulikflüssigkeit füllen.
- Vor Inbetriebnahme ist das Pumpengehäuse und das Hydrauliksystem mit dem empfohlenen Hydrauliköl zu füllen.
- Füllen Sie die Pumpe mindestens auf 50 % mit Öl (da die interne Leckage beim Start keine ausreichende Schmierung bietet) indem Sie:
 - a) Hydrauliköl direkt in die Pumpe füllen, oder
 - b) Hydrauliköl vom Öltank in die Pumpe füllen:
- Öffnen des Absperrventils zwischen Öltank und Pumpe (wenn vorhanden)
- Leckölstopfen an der Pumpe herausschrauben und warten bis Hydrauliköl austritt
- Leckölstopfen wieder einschrauben.

5) Avant le démarrage

- Assurez-vous que tout le système hydraulique est propre avant de le remplir avec un fluide hydraulique recommandé.
- Toujours remplir la pompe (et la totalité du système hydraulique) avec une huile recommandée avant le démarrage.
- Remplir la pompe à au moins 50 % (car la fuite interne n'assure pas une lubrification suffisante au démarrage) d'huile soit :
 - a) Remplir directement la pompe
 - b) Si le réservoir est au dessus de la pompe:
- Ouvrir la vanne d'isolement entre le réservoir et la pompe (si elle existe)
- Retirer le bouchon sur la pompe et attendre que l'huile coule
- Remettre le bouchon.

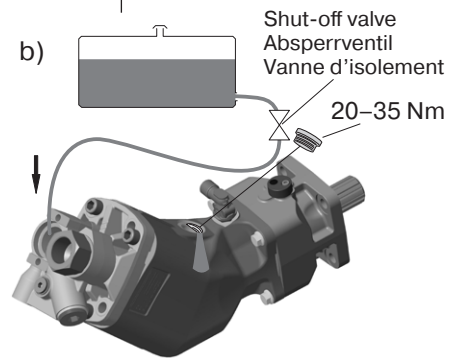
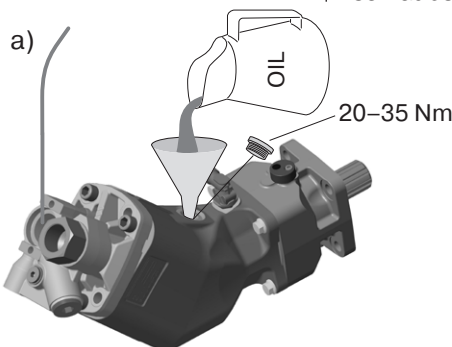

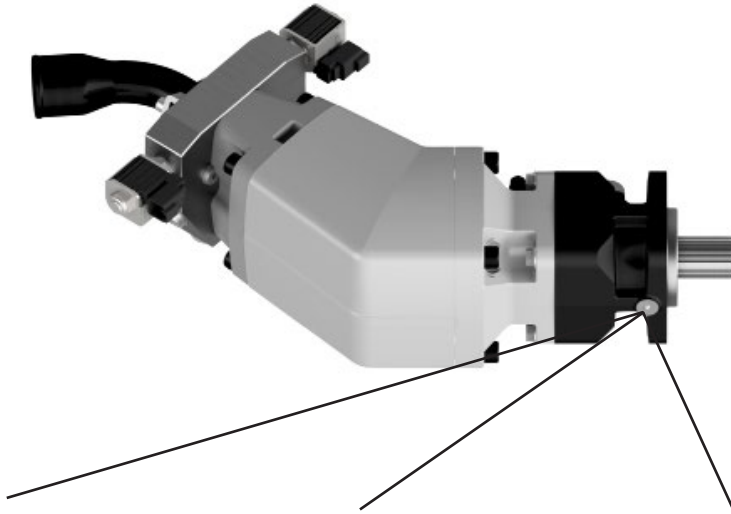

6) If any oil should come out of the indication-hole on the pump;

- Stop the system immediately.
- Determine the cause of leakage.
- Replace damaged parts.
- Make sure you have corrected the source of the problem, not only the symptom.

Parker can not be held responsible for damage to PTO, engine and gearbox caused by improper maintenance of the hydraulic system.

6) Falls Öl aus der Anzei-
geöffnung der Pumpe
austreten sollte:

- Die Anlage sofort abschalten.
- Die Ursache der Undich-
tigkeit ermitteln.
- Beschädigte Teile
austauschen.
- Sicherstellen, dass die
Ursache des Problems
und nicht nur das Symp-
tom beseitigt wurde.

Parker übernimmt keinerlei Haftung für Beschädigungen an Nebenantrieben, Motor und Getriebe, die durch unsachgemäße Wartung der Hydraulikanlage entstanden sind.

6) En cas de fuite d'huile
par l'orifice indicateur de
la pompe :

- Arrêtez immédiatement le système.
- Déterminez la cause de la fuite.
- Remplacez les pièces endommagées.
- Assurez-vous que vous avez bien remédié à la cause de la fuite et non uniquement au symptôme.

Parker ne saurait être tenu responsable d'un dommage survenu à la prise de force, au moteur ou à la boîte de vitesse, dû au mauvais entretien du circuit hydraulique.

7) Fluids

Type HLP (according to DIN 51524) hydraulic oil is suitable as well as biologically degradable fluids like natural and synthetic esters and polyalphaolefins. The utilised hydraulic fluid shall meet one of the following Swedish standards:

- SS 15 54 34
- SMR 1996-2.

Contact Parker Hannifin for further information.

NOTE:

- ATF (automatic transmission fluid) and API type CD engine oils may also be useable.
- Seals are made of Viton; make sure the Viton utilised fluid is compatible with this material.

Fluid temperature

Main circuit: Max 75 °C.

Drain line

Fixed displacement pumps don't need an external drain line as they are internally drained.

When the pump is mounted in a Engine-PTO we recommend a drain line from the bypass valve directly to oil tank.

7) Hydraulikflüssigkeiten

Zulässig sind HLP-Hydrauliköl (DIN 51524) sowie biologisch abbaubare Flüssigkeiten, wie z.B. natürliche oder künstliche Ester und Polyalphaolefine. Die Hydraulikflüssigkeiten sollen eine der folgenden schwedischen Normen erfüllen:

- SS 15 54 34
- SMR 1996-2.

Weitere Informationen erteilt Parker Hannifin.

Beachte:

- Automatiköle Typ ATF und Maschinenöle Typ API CD können ebenfalls verwendet werden.
- Die Dichtungen bestehen aus Viton. Stellen Sie sicher, dass die verwendete Viton-Flüssigkeit mit diesem Material kompatibel ist.

Betriebstemperatur

Systemflüssigkeit: max. 75 °C.

Leckölleitung

Pumpen mit konstantes Verdrängungsvolumen werden intern drainiert. Eine externe Leckölleitung ist daher nicht erforderlich.

Wenn die Pumpe auf einen Nebenantrieb montiert wird, empfiehlt sich eine Drainage-Leitung vom Bypass-Ventil zum Tank.

7) Fluides

Les fluides hydrauliques du type HLP (DIN 51524) conviennent, de même que les liquides biodégradables tels que les esters naturels et synthétiques ainsi que les polyalpha-oléfines. Utiliser un fluide qui satisfait à une des normes suédoises suivantes :

- SS 15 54 34
- SMR 1996-2.

Pour tous renseignements supplémentaires, contacter Parker Hannifin.

Nota :

- Les huiles pour boîtes de vitesses automatiques (ATF) et les huiles moteur API de type CD peuvent aussi être utilisées.
- Les étanchéités sont en Viton. Vérifier que le fluide choisi est compatible avec ce matériau.

Température de l'huile hydraulique

Circuit principal : 75 °C maxi.

Tuyau de drain

Les pompes F4 n'ont pas besoin d'un conduit de drain vers le réservoir car elles sont drainées intérieurement. Quand la pompe est montée sur une prise de force de boîte de vitesses, nous recommandons une ligne drainage de la valve de bypass, reliée directement au réservoir.

Position notification regarding Machinery Directive 2006/42/EC:

Products made by the Pump & Motor Division Europe (PMDE) of Parker Hannifin are excluded from the scope of the machinery directive following the "Cetop" Position Paper on the implementation of the Machinery Directive 2006/42/EC in the Fluid Power Industry.

All PMDE products are designed and manufactured considering the basic as well as the proven safety principles according to:

- ISO 13849-1:2015
- SS-EN ISO 4413:2010

so that the machines in which the products are incorporated meet the essential health and safety requirements.

Confirmations for components to be proven component, e.g. for validation of hydraulic systems, can only be provided after an analysis of the specific application, as the fact to be a proven component mainly depends on the specific application.

Christian Jäger

General Manger

Pump & Motor Division Europe

**WARNING – USER RESPONSIBILITY**

FAILURE OR IMPROPER SELECTION OR IMPROPER USE OF THE PRODUCTS DESCRIBED HEREIN OR RELATED ITEMS CAN CAUSE DEATH, PERSONAL INJURY AND PROPERTY DAMAGE.

This document and other information from Parker-Hannifin Corporation, its subsidiaries and authorized distributors provide product or system options for further investigation by users having technical expertise.

The user, through its own analysis and testing, is solely responsible for making the final selection of the system and components and assuring that all performance, endurance, maintenance, safety and warning requirements of the application are met. The user must analyze all aspects of the application, follow applicable industry standards, and follow the information concerning the product in the current product catalogue and in any other materials provided from Parker or its subsidiaries or authorized distributors.

To the extent that Parker or its subsidiaries or authorized distributors provide component or system options based upon data or specifications provided by the user, the user is responsible for determining that such data and specifications are suitable and sufficient for all applications and reasonably foreseeable uses of the components or systems.

Offer of Sale

Please contact your Parker representation for a detailed "Offer of Sale".

Parker Hannifin Manufacturing Sweden AB

Pump & Motor Division Europe

Flygmotorvägen 2

461 82 Trollhättan

Sweden

Tel. +46 (0)520 40 45 00

www.parker.com/pmde

MSG30-8202-INST/UK/DE/FR

Art. No 3720290-04



© Copyright 2023

All rights reserved