



Operation Manual

PRODUCT NAME

Regulator

MODEL / Series / Product Number

AR20(K)-(F,N)01 ~ (F,N)02(B,E,E1,E2,E3,E4,G,H,M)(-1,N,R,Y,Z,ZA)-D

AR30(K)-(F,N)02 ~ (F,N)03(B,E,E1,E2,E3,E4,G,H,M)(-1,N,R,Y,Z,ZA)-D

AR40(K)-(F,N)02 ~ (F,N)04(B,E,E1,E2,E3,E4,G,H,M)(-1,N,R,Y,Z,ZA)-D

AR40(K)-(F,N)06(B,E,E1,E2,E3,E4,G,H,M)(-1,N,R,Y,Z,ZA)-D

AR50(K)-(F,N)06 ~ (F,N)10(B,E,E1,E2,E3,E4,G,M)(-1,N,R,Y,Z,ZA)-D

AR60(K)-(F,N)10(B,E,E1,E2,E3,E4,G,M)(-1,N,R,Y,Z,ZA)-D

SMC Corporation

Contents

	Page
1. Safety Instructions	2-6
2. Application	7
3. Standard Specifications	7
4. How to Order	8
5. Options	9
6. Structural Drawing and Replacement Parts	10
7. Assembly of Optional Parts	11-12
8. Operation and Adjustment	13
9. Trouble Shooting	14-15
10. How to Replace the Components	16-22
10-1. Diaphragm Assembly Replacement	16
10-2. Valve Guide Assembly and Valve Assembly Replacement	17
10-3. Square Embedded Type Pressure Gauge Replacement	18
10-4. Blanking Plate Assembly Replacement	19
10-5. Check Valve Assembly Replacement	20
10-6. Plug Assembly Replacement 【AR20 (K) to 60 (K)】	21
10-7. Plug Assembly Replacement 【AR20K to 60K】	22
11. Disassembly Drawing	23-25
12. Dimensions	26-28



Safety Instructions

These safety instructions are intended to prevent hazardous situations and/or equipment damage. These instructions indicate the level of potential hazard with the labels of "Caution," "Warning" or "Danger." They are all important notes for safety and must be followed in addition to International Standards (ISO/IEC)*1), and other safety regulations.

*1) ISO 4414: Pneumatic fluid power -- General rules relating to systems.

ISO 4413: Hydraulic fluid power -- General rules relating to systems.

IEC 60204-1: Safety of machinery -- Electrical equipment of machines .(Part 1: General requirements)

ISO 10218: Manipulating industrial robots -Safety.

etc.



Caution

Caution indicates a hazard with a low level of risk which, if not avoided, could result in minor or moderate injury.



Warning

Warning indicates a hazard with a medium level of risk which, if not avoided, could result in death or serious injury.



Danger

Danger indicates a hazard with a high level of risk which, if not avoided, will result in death or serious injury.

Warning

1. The compatibility of the product is the responsibility of the person who designs the equipment or decides its specifications.

Since the product specified here is used under various operating conditions, its compatibility with specific equipment must be decided by the person who designs the equipment or decides its specifications based on necessary analysis and test results.

The expected performance and safety assurance of the equipment will be the responsibility of the person who has determined its compatibility with the product.

This person should also continuously review all specifications of the product referring to its latest catalog information, with a view to giving due consideration to any possibility of equipment failure when configuring the equipment.

2. Only personnel with appropriate training should operate machinery and equipment.

The product specified here may become unsafe if handled incorrectly.

The assembly, operation and maintenance of machines or equipment including our products must be performed by an operator who is appropriately trained and experienced.

3. Do not service or attempt to remove product and machinery/equipment until safety is confirmed.

1. The inspection and maintenance of machinery/equipment should only be performed after measures to prevent falling or runaway of the driven objects have been confirmed.

2. When the product is to be removed, confirm that the safety measures as mentioned above are implemented and the power from any appropriate source is cut, and read and understand the specific product precautions of all relevant products carefully.

3. Before machinery/equipment is restarted, take measures to prevent unexpected operation and malfunction.

4. Contact SMC beforehand and take special consideration of safety measures if the product is to be used in any of the following conditions.

1. Conditions and environments outside of the given specifications, or use outdoors or in a place exposed to direct sunlight.

2. Installation on equipment in conjunction with atomic energy, railways, air navigation, space, shipping, vehicles, military, medical treatment, combustion and recreation, or equipment in contact with food and beverages, emergency stop circuits, clutch and brake circuits in press applications, safety equipment or other applications unsuitable for the standard specifications described in the product catalog.

3. An application which could have negative effects on people, property, or animals requiring special safety analysis.

4. Use in an interlock circuit, which requires the provision of double interlock for possible failure by using a mechanical protective function, and periodical checks to confirm proper operation.



Safety Instructions

Caution

The product is provided for use in manufacturing industries.

The product herein described is basically provided for peaceful use in manufacturing industries.

If considering using the product in other industries, consult SMC beforehand and exchange specifications or a contract if necessary.

If anything is unclear, contact your nearest sales branch.

Limited warranty and Disclaimer/Compliance Requirements

The product used is subject to the following “Limited warranty and Disclaimer” and “Compliance Requirements”.

Read and accept them before using the product.

Limited warranty and Disclaimer

1. The warranty period of the product is 1 year in service or 1.5 years after the product is delivered, whichever is first.*2)

Also, the product may have specified durability, running distance or replacement parts. Please consult your nearest sales branch.

2. For any failure or damage reported within the warranty period which is clearly our responsibility, a replacement product or necessary parts will be provided.

This limited warranty applies only to our product independently, and not to any other damage incurred due to the failure of the product.

3. Prior to using SMC products, please read and understand the warranty terms and disclaimers noted in the specified catalog for the particular products.

*2) Vacuum pads are excluded from this 1 year warranty.

A vacuum pad is a consumable part, so it is warranted for a year after it is delivered.

Also, even within the warranty period, the wear of a product due to the use of the vacuum pad or failure due to the deterioration of rubber material are not covered by the limited warranty.

Compliance Requirements

1. The use of SMC products with production equipment for the manufacture of weapons of mass destruction(WMD) or any other weapon is strictly prohibited.

2. The exports of SMC products or technology from one country to another are governed by the relevant security laws and regulation of the countries involved in the transaction. Prior to the shipment of a SMC product to another country, assure that all local rules governing that export are known and followed.

Caution

SMC products are not intended for use as instruments for legal metrology.

Measurement instruments that SMC manufactures or sells have not been qualified by type approval tests relevant to the metrology (measurement) laws of each country.

Therefore, SMC products cannot be used for business or certification ordained by the metrology (measurement) laws of each country.

Precautions for Design

Warning

- (1) Polyacetal resin parts are used for the exterior. Organic solvents including thinner, acetone, alcohol and ethylene chloride; chemicals including sulphuric acid, nitric acid and hydrochloric acid; cutting oil, synthetic oils, ester-based compressor oil, alkali, kerosene, gasoline, lock material of screw are harmful. Do not use the product where these are present.
- (2) Consult SMC if no leakage is allowed due to the environment, or if the operating fluid is not air.
- (3) Shield from ultra violet light and radiation with protective cover.
- (4) A safety device needs to be installed if output pressure is exceeding the set pressure, otherwise this can cause breakage of outlet device and equipment or lead to malfunction.

Caution

- (1) Allowed air consumption from the exhaust port is 0.1 L/min(ANR) or less.

Selection

Warning

- (1) Grease used on the internal sliding parts and seals may flow to the outlet side. If this is not acceptable, please consult SMC.
- (2) Residual pressure of product without backflow function is released unstably even though the inlet pressure is released (residual pressure might be left in the product). Please select product with backflow function to release the residual pressure completely.
- (3) Long absence of operation or operation with sealed circuit or balancing circuit on the outlet side may cause set pressure fluctuation. Please consult SMC if this is not acceptable.
- (4) Set range of outlet pressure shall be 85% or less of the inlet pressure. Operating at a setting exceeding 85% causes the outlet pressure to be easily affected by fluctuations in flow rate and inlet pressure, leading to instability.
- (5) Since the safety margin is calculated to the maximum value of the set pressure range shown in the specification table, the pressure setting may be over the maximum value. However, use the product within the specified range.
- (6) If the product is used with circuit which requires high exhaust sensitivity or set precision, please consult SMC.

Installation

Warning

- (1) Connect the product ensuring the direction of "1"(IN) and "2"(OUT) for air direction and indicated arrow. Incorrect connections may cause malfunction.
- (2) Install with enough space around the regulator to perform regular maintenance and operation. Refer to the dimensional drawings (P26-28) for necessary space.
- (3) Do not drop or apply impact during transportation or installation. Damage of products or pressure gauge can result in malfunction.
- (4) Do not install in areas with high humidity or high temperature. It may lead to a malfunction of the pressure gauge.

Adjustment

Warning

- (1) Adjust the set pressure ensuring correct inlet and outlet pressures. Turning the knob excessively can cause damage to the internal parts.
- (2) Do not use tools on the pressure regulator knob as this may cause damage. It must be operated manually.

Caution

- (1) For the product with a pressure gauge, do not apply pressure exceeding the maximum scale of the pressure gauge in order to protect the gauge.
- (2) Adjust the pressure whilst the pressure is increasing. Pressure may become lower than the set pressure if adjusted by decreasing the value. Rotate the knob clockwise to increase the set pressure. Counterclockwise to decrease the pressure. Moreover, please lock the knob after setting pressure.
- (3) For the regulator with backflow function, upstream pressure needs to be higher than downstream pressure by 0.05 MPa or more.
- (4) Outlet pressure may rise when the inlet pressure is discharged and resupplied after pressure setting. In this case, consume air at the outlet which will bring the pressure closer to the set pressure.
- (5) Outlet pressure may change if the product is used for a long period of time. Please confirm the set pressure regularly.
- (6) When pressure difference between the inlet side and the outlet side is large, chattering may occur. In that case, please reduce the pressure difference between the inlet and the outlet. Please consult SMC if chattering continues.

Piping

Warning

- (1) Before piping is connected, it should be thoroughly blown out with air (flushing) or washed to remove chips, cutting oil and solid foreign material from inside the pipe. Contamination of piping may cause damage or malfunction.
- (2) When screwing together pipes and fittings, etc., be certain that chips from the pipe threads and sealant do not get inside the pipe. When a sealant tape is used, leave 1.5 to 2 thread ridges exposed at the end of the threads.
- (3) Connect piping/fittings using the recommended torque while holding the female thread side tightly. Insufficient tightening torque leads to cause of loosening or sealing failure, and excessive tightening torque leads to cause of breakage of screws. Tightening without holding female thread applies an excessive force to the piping bracket directly, leading to breakage.

Recommended tightening torque						Unit: N m
Thread size	1/8	1/4	3/8	1/2	3/4	1
Torque	7 to 9	12 to 14	22 to 24	28 to 30	28 to 30	36 to 38

- (4) Before using an SMC fitting and S coupler, please refer to "Tightening the threaded portion of the connection thread" of the Fittings & Tubing Precautions.
- (5) Do not apply torsion or bending moment other than the weight of the product itself. External piping needs to be supported separately as it may cause breakage. Non-flexible piping like steel tube is susceptible to excessive moment load or vibration. Insert flexible tubes to prevent this.

Air Source

Warning

- (1) Use clean air. Do not use compressed air containing chemicals, organic solvent, synthetic oil or corrosive gas as it may be cause of breakage of components or operation failure.
- (2) Air containing too much moisture may cause malfunction. Install an air drier or aftercooler before the regulator.

Maintenance

Warning

- (1) Release the pressure in the product to the atmosphere when replacing parts or removing piping.
- (2) Maintenance and checks should be done by following the procedure in this operation manual. Incorrect handling of the product may cause breakage or operation failure of the equipment or device.
- (3) When using the regulator with backflow function between a solenoid valve and an actuator, check the pressure gauge periodically. Sudden pressure fluctuations may shorten the durability of the pressure gauge. A digital pressure gauge is recommended for such applications or as deemed necessary.

Caution

- (1) If an emergency countermeasure is to be taken during setting failure or exhaust leakage, the internal valve seating part should be checked. If failure such as foreign matter is found, remove it before performing the emergency countermeasure.

2. Application

This product aims at controlling pressure of air lines.

3. Standard Specifications

Model	AR20-D	AR30-D	AR40-D	AR40-06-D	AR50-D	AR60-D
Port size	1/8, 1/4	1/4, 3/8	1/4, 3/8, 1/2	3/4	3/4, 1	1
Pressure gauge port size ^{Note 1)}	1/8					
Fluid	Air					
Ambient and fluid temperature ^{Note 2)}	-5 to 60°C (with no freezing)					
Proof pressure	1.5 MPa					
Max. operating pressure	1.0 MPa					
Set pressure range	0.05 to 0.85 MPa					
Construction	Relieving type					
Weight	0.14kg	0.27kg	0.48kg	0.51kg	1.13kg	1.25kg

Note 1) Pressure gauge connection threads are not available for product with a square embedded type pressure gauge or with a digital pressure switch.

Note 2) -5 to 50°C for the products with the digital pressure switch.

4. How to Order

AR **30** **K** - **03** **BE** - **D**

① ② ③ ④ ⑤ ⑥

		Symbol	Description	①					
				Body size					
				20	30	40	50	60	
②	With backflow function	Nil	Without backflow function	●	●	●	●	●	
		K	With backflow function	●	●	●	●	●	
③	Thread type	Nil	Rc	●	●	●	●	●	
		N	NPT	●	●	●	●	●	
		F	G	●	●	●	●	●	
④	Port size	01	1/8	●	—	—	—	—	
		02	1/4	●	●	●	—	—	
		03	3/8	—	●	●	—	—	
		04	1/2	—	—	●	—	—	
		06	3/4	—	—	●	●	—	
		10	1	—	—	—	●	●	
⑤	a	Mounting	Nil	Without mounting option	●	●	●	●	●
			B	With bracket	●	●	●	●	●
			H	With set nut (for panel mount)	●	●	●	—	—
	b	Pressure gauge	Nil	Without pressure gauge	●	●	●	●	●
			E	Square embedded type pressure gauge (with limit indicator)	●	●	●	●	●
			G	Round type pressure gauge (with limit indicator)	●	●	●	●	●
			M	Round type pressure gauge (with color zone)	●	●	●	●	●
		Digital pressure switch	E1	NPN output / Wiring bottom entry	●	●	●	●	●
			E2	NPN output/ Wiring top entry	●	●	●	●	●
			E3	PNP output / Wiring bottom entry	●	●	●	●	●
		E4	PNP output/ Wiring top entry	●	●	●	●	●	
⑥	c	Set pressure	Nil	0.05 to 0.85 MPa setting	●	●	●	●	●
			1	0.02 to 0.2 MPa setting	●	●	●	●	●
	d	Exhaust mechanism	Nil	Relieving type	●	●	●	●	●
			N	Non-relieving type	●	●	●	●	●
	e	Flow direction	Nil	Flow direction: Left to right	●	●	●	●	●
			R	Flow direction: Right to left	●	●	●	●	●
	f	Knob	Nil	Downward	●	●	●	●	●
			Y	Upward	●	●	●	●	●
	g	Unit indication	Nil	Pressure unit: MPa Temp. unit: °C	●	●	●	●	●
			Z	Pressure unit: psi Temp. unit: °F	○ Note 2)	○ Note 2)	○ Note 2)	○ Note 2)	○ Note 2)
ZA			Digital pressure switch: With unit selection function	△ Note 3)	△ Note 3)	△ Note 3)	△ Note 3)	△ Note 3)	

Note 1) ⑤Option and ⑥Semi-standard: Select one each for a to g.

Note 2) ○: For NPT thread type only.

Note 3) △: Select with an option E1, E2, E3 or E4.

5. Options

Without pressure gauge/
With round type pressure gauge
(Backflow function: No)

Without pressure gauge/
With round type pressure gauge
(Backflow function: Yes)

With square embedded type pressure gauge/
With digital pressure switch
(Backflow function: No/Yes)

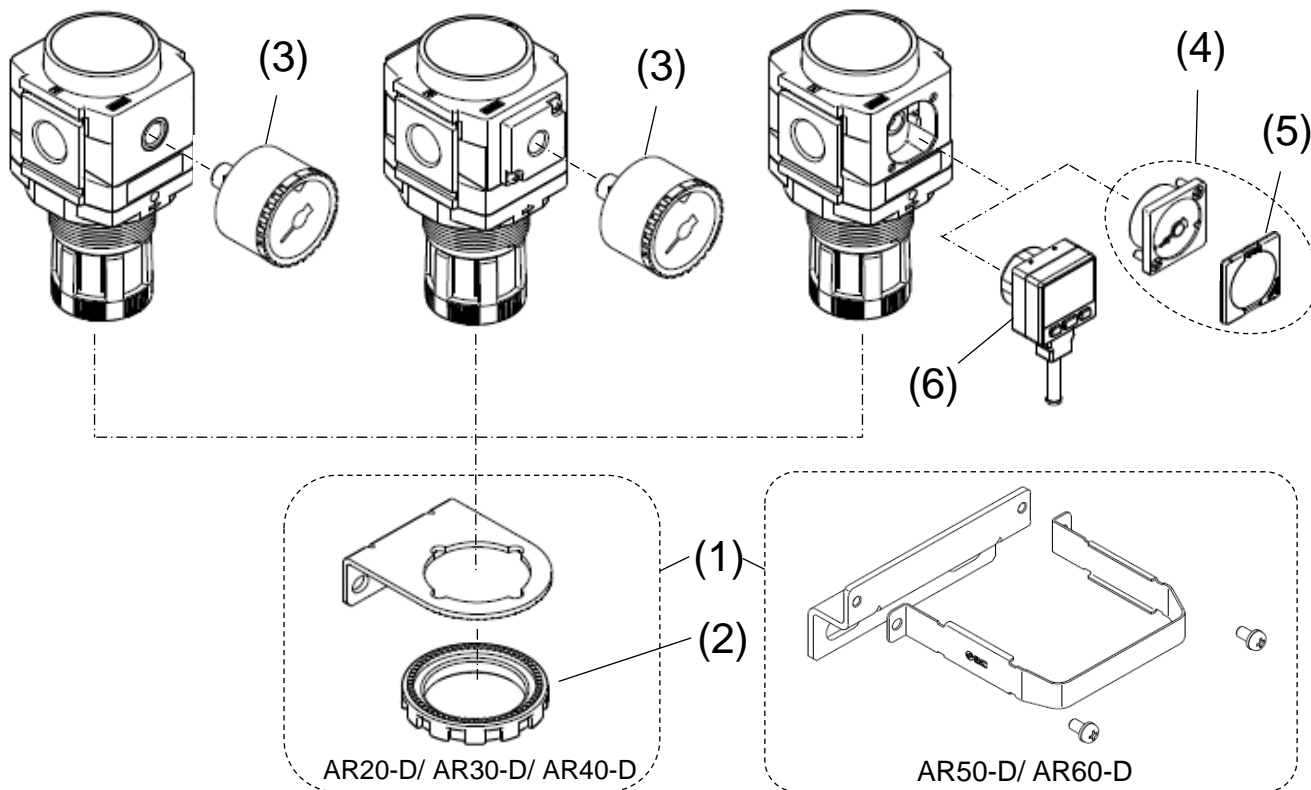

Options

No.	Part name	Piping thread type	Semi-standard specification	Part No.							
				AR20-D	AR30-D	AR40-D	AR40-06-D	AR50-D	AR60-D		
(1)	Bracket assembly ^{Note 1)}	—	—	AR23P-270AS	AR33P-270AS	AR43P-270AS		AR54P-270AS ^{Note 4)}			
(2)	Set nut	—	—	AR23P-260S	AR33P-260S	AR43P-260S			—		
(3)	Pressure gauge ^{Note 2)} (Round type)	Rc	—	G36-10-01		G46-10-01					
		NPT	—	G36-10-N01		G46-10-N01					
			Z : Both in MPa and psi	G36-P10-N01-X30		G46-P10-N01-X30					
	Pressure gauge ^{Note 2)} (Round type, with color zone)	G	—	G36-10-01		G46-10-01					
		NPT	—	G36-10-01-L		G46-10-01-L					
			G	—	G36-10-N01-L		G46-10-N01-L				
(4)	Square embedded type pressure gauge ^{Note 3)}	—	—	GC3-10AS-D							
		NPT	Z : Both in MPa and psi	GC3-P10AS-D-X30							
(5)	Pressure gauge cover assembly	—	—	136150A							
(6)	Digital pressure switch (with accessories for mounting)	—	—	<Common for all sizes>							
				Output specification		Bottom entry wiring		Top entry wiring			
				NPN		ISE35-N-25-MLA-X523		ISE35-R-25-MLA-X523			
				PNP		ISE35-N-65-MLA-X523		ISE35-R-65-MLA-X523			
				—	ZA : Unit selection function	NPN		ISE35-N-25-LA-X523		ISE35-R-25-LA-X523	
						PNP		ISE35-N-65-LA-X523		ISE35-R-65-LA-X523	
				NPT	Z : Unit selection function Initial setting: psi	NPN		ISE35-N-25-PLA-X523		ISE35-R-25-PLA-X523	
PNP		ISE35-N-65-PLA-X523				ISE35-R-65-PLA-X523					

Note) The numbers in the table and structural drawings are consistent with the numbers in sections [10. How to Replace the Components] (P16-22) and [11. Disassembly Drawing] (P23-25).

Note1) This is an assembly of a bracket and set nut (2).

Note 2) Part number for 0.2 MPa: G36-4-01 (Rc type) / G36-4-N01 (NPT type) / G36-P4-N01-X30 (NPT, Z type).

G46-4-01 (Rc type) / G46-4-N01 (NPT type) / G46-P4-N01-X30 (NPT, Z type).

Note 3) With O-ring (1 pc.) and mounting screws (2 pcs.). Part number for 0.2 MPa: GC3-4AS-D (Rc, NPT type) / GC3-P4AS-D-X30 (NPT, Z type).

Note 4) Assembly of 2 types of bracket and 2 set screws.

6. Structural Drawing and Replacement Parts

Construction/ Common replacement parts

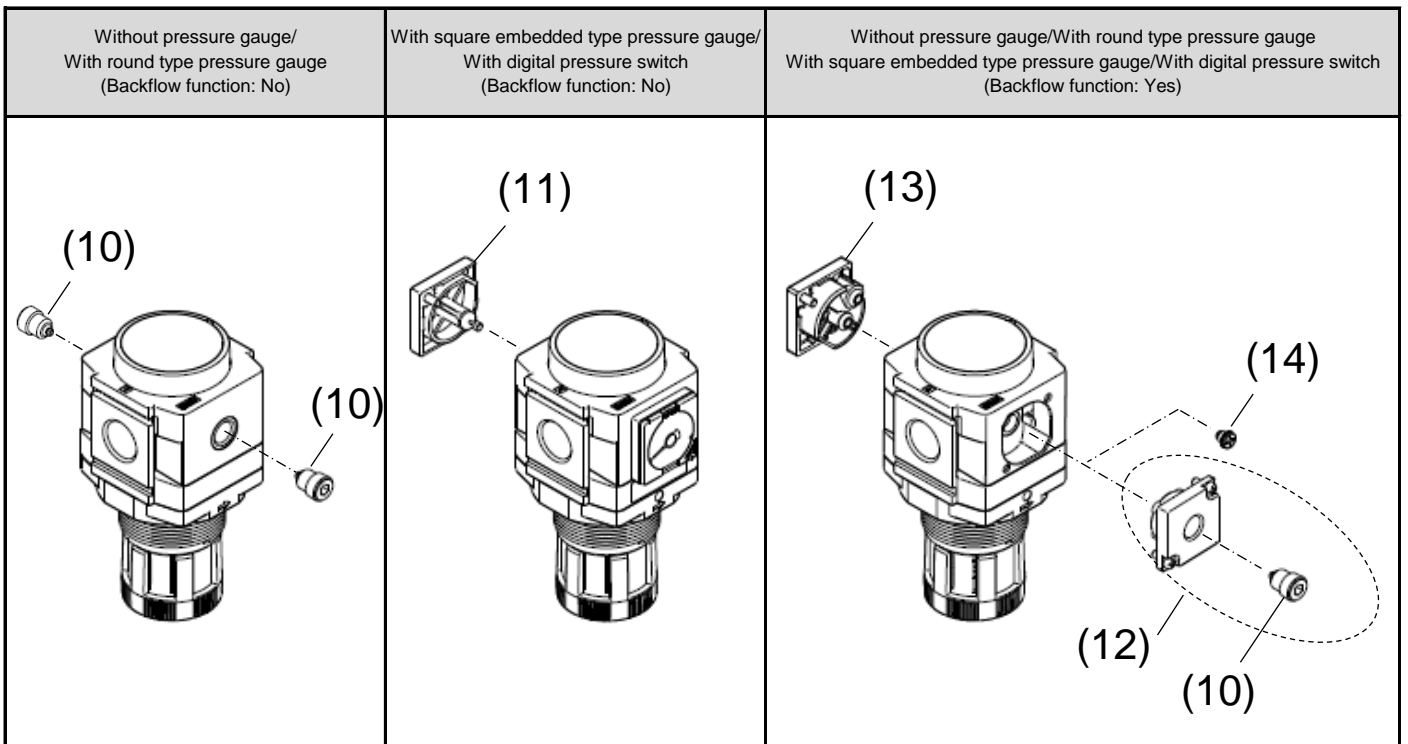
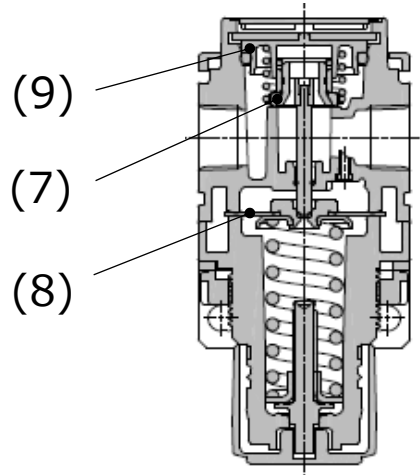

Replacement parts

No.	Part name	Piping thread type	Semi-standard specification	Part No.					
				AR20-D	AR30-D	AR40-D	AR40-06-D	AR50-D	AR60-D
(7)	Valve assembly	—	—	AR24P-060AS	AR34P-060AS	AR44P-060AS	AR49P-060AS	AR54P-060AS	AR64P-060AS
(8)	Diaphragm assembly	—	— : Relief	AR24P-150AS	AR34P-150AS	AR44P-150AS		AR54P-150AS	
			N : Non-relief	AR24P-150AS-N	AR34P-150AS-N	AR44P-150AS-N		AR54P-150AS-N	
(9)	Valve guide assembly	—	—	AR24P-050AS	AR34P-050AS	AR44P-050AS		AR54P-050AS	
(10)	Plug assembly	Rc/G	—	AR24P-370AS-01					
		NPT	—	AR24P-370AS-N01					
(11)	Blanking plate assembly	—	—	AR24P-250AS					
(12)	Plug assembly (Including part (10))	Rc	—	AR24P-320AS-01					
		NPT	—	AR24P-320AS-N01					
		G	—	AR24P-320AS-F01					
(13)	Check valve assembly	—	—	AR24KP-020AS					
(14)	Check valve plug assembly	—	—	AR20KP-090AS					

Note) The numbers in the table and structural drawings are consistent with the numbers in sections [10. How to Replace the Components] (P16-22) and [11. Disassembly Drawing] (P23-25).

7. Assembly of Optional Parts

7-1. AR20-D/ AR30-D/ AR40-D Bracket (Panel mount)

1) Bracket mounting
Mount the bracket to the regulator as shown in the picture. Assemble so that the rotation stopper of the regulator and the bracket are engaged properly.

2) Secure with the set nut
Ensure that the knurled faces of the bracket and the set nut are facing each other.

3) Tightening
Turn the set nut while the regulator is aligned correctly with the bracket. The knurling of the bracket and set nut stops loosening of the screw. Usually, these can be tightened adequately by hand. (Extra tightening is recommended for panel mounting).

* When retightening
Please use a hook wrench on the grooves of the set nut. After hand tightening, follow the values in the table below for retightening.

Model	Tool size	Amount of retightening	Reference torque
AR20-D	34/38	2 to 5 notch	2.0+/-0.2 N m
AR30-D	52/55		3.5+/-0.3 N m
AR40-D	52/55		4.0+/-0.4 N m

7-2. AR50-D/ AR60-D Bracket

1) Mounting of bracket A
Insert bracket A from the front of the regulator so that the fingers of the bracket A hold the regulator at the groove and the bottom of the body.

2) Mounting of bracket B
Fix the bracket B with the set screw (2 pcs.) included in the package. Refer to the table below for the tightening torque.

Model	Tool	Reference torque
AR50-D	Phillips screwdriver	1.5+/-0.2 N m
AR60-D		

7-3. Pressure gauge (round type)

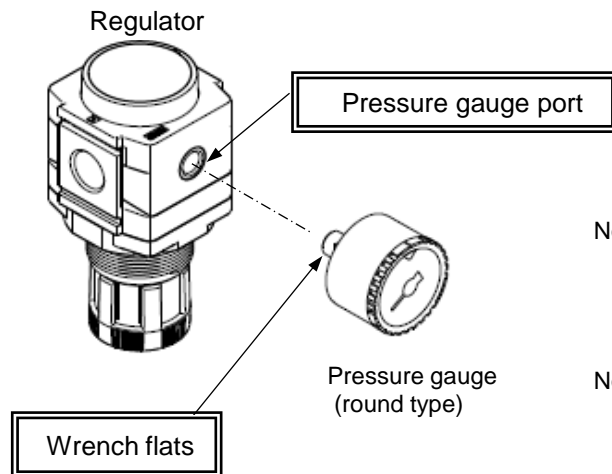

- 1) Pressure gauge mounting (round type)
 Before mounting the pressure gauge onto the pressure gauge port of the regulator, confirm that sealing material has been applied to the pressure gauge.
 Please refer to "Piping" on page 5 when using sealing tape.

Wrench size

Model	Tool size
AR20-D	14
AR30-D	
AR40-D	
AR50-D	
AR60-D	

- Note 1) Positioning of pressure gauge
 Adjust the pressure gauge position by tightening it.
 Adjustment in loosening direction may cause air leakage.
- Note 2) No plug is mounted onto the pressure gauge port of product with a round type pressure gauge.
- Note 3) Torque control
 Please use the value in the torque table described in "Piping" on page 5 when controlling the tightening torque.

8. Operation and Adjustment

8-1. Pressure regulation

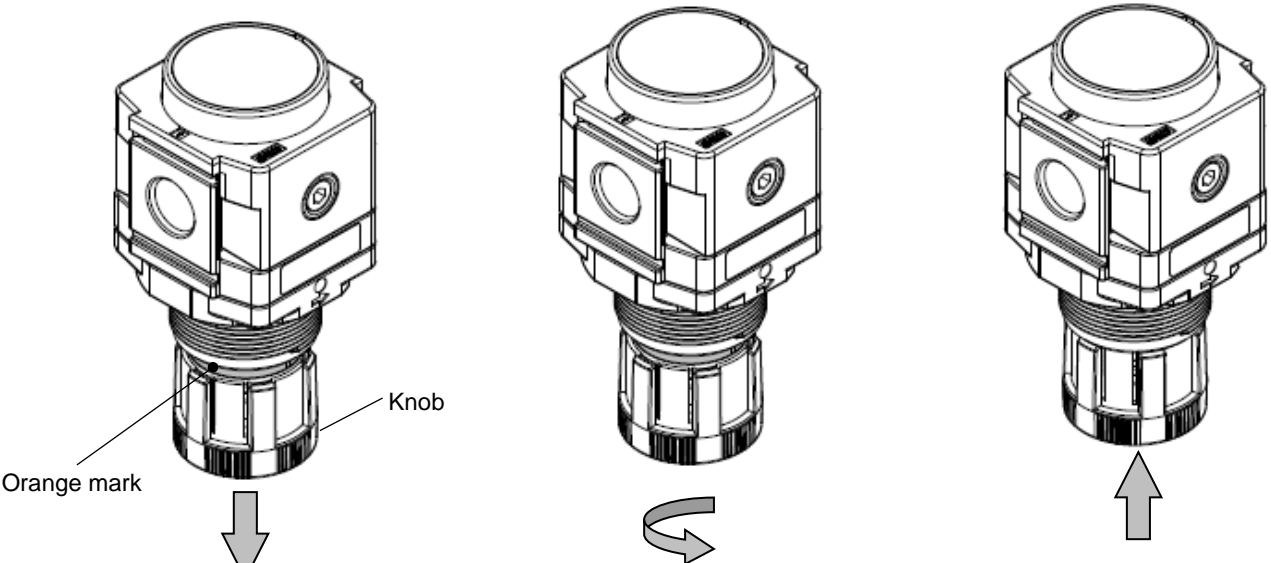

Orange mark

Knob

(1) Pull the knob in the arrow direction for unlocking, revealing an orange mark.

(2) Turning the knob clockwise increases the outlet pressure. When the knob of the relief type is rotated counterclockwise, pressure decreases.
Note) Adjust the pressure in pressure increasing direction (rotate in the arrow direction). Otherwise, it may cause insufficient set pressure.

(3) After adjusting pressure, lock the knob by pushing it in the arrow direction.

8-2. Indicator adjustment of the square embedded type pressure gauge

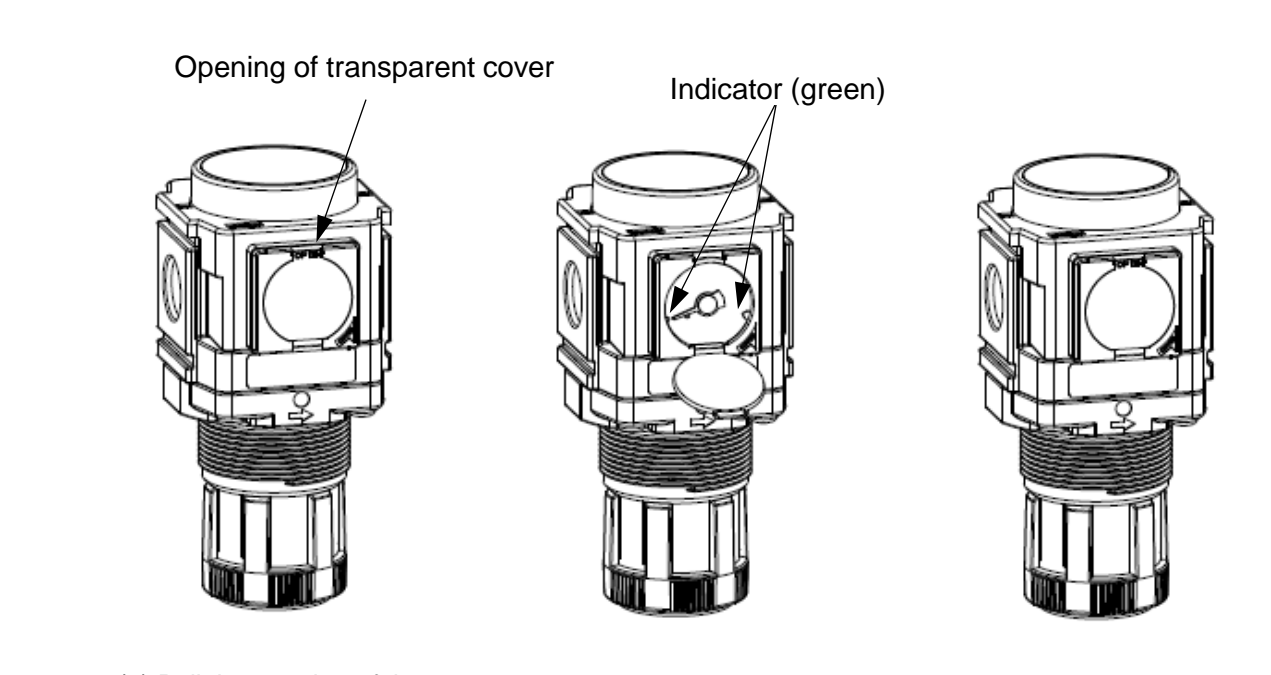

Opening of transparent cover

Indicator (green)

(1) Pull the opening of the transparent cover to unlock.

(2) Open the transparent cover as in the drawing and adjust the indicator to the upper and lower limit positions to be controlled.

(3) Close the transparent cover after adjusting the indicator.

9. Trouble Shooting

Refer to sections [10. How to Replace the Components] (P16-22) and [11. Disassembly Drawing] (P23-25).

Trouble		Possible cause	Countermeasure	Page for reference	
Category	Failure				
Pressure	The pressure can not be adjusted.	1. Air pressure is not supplied to the inlet.	Check the supply pressure. Ensure that the supply side ball valve is opened.	—	
		2. The product is installed opposite to the flow direction.	Install the product correctly after confirming the direction of flow. "1" indicates the IN and "2" indicates the OUT.	—	
		3. Pressure regulating spring is damaged.	Replace the pressure regulating spring.	P16	
		4. Valve spring is damaged.	Replace the valve spring.	P17	
		5. Foreign materials caught in the rubber seat of the valve or the O-ring on the valve sliding part.	Replace the valve guide assembly and valve assembly.	P17	
		6. Seating part of the valve is damaged.	Replace the valve assembly.	P17	
		7. Foreign materials caught in the seating part of the check valve.	Replace the check valve assembly.	P20	
	The set pressure does not become zero even when the knob is loosened.	1. Foreign materials caught in the seating part or O-ring of the valve.	Remove the valve and eliminate foreign materials. When the condition is not improved, replace the valve guide assembly and valve assembly.	P17	
		2. Rubber seat of the valve is damaged.	Replace the valve assembly.	P17	
		3. Valve spring is damaged.	Replace the valve spring.	P17	
		4. The valve is fixed in an opened position.	Clean the valve sliding surface of O-ring and apply grease additionally.	P17	
	Air leakage	Air leaks from the bonnet exhaust port.	1. The product is installed opposite to the flow direction.	Install the product correctly after confirming the direction of flow.	—
			2. Diaphragm is damaged.	Replace the diaphragm assembly.	P16
			3. Foreign materials caught in seating part of the exhaust valve.	Clean the seating part of the relief valve or replace the diaphragm assembly.	P16
4. Foreign materials caught in the seating part or O-ring of the valve.			Remove the valve guide to clean the valve, valve seating part and valve O-ring. And then, apply grease to the O-ring and sliding part of the valve.	P17	
5. Rubber seat of the valve assembly is damaged.			Replace the valve assembly.	P17	
6. Foreign materials caught in the seating part of the check valve.			Replace the check valve assembly.	P20	

Note) Fluorine grease is recommended when applying additional grease.

Refer to sections [10. How to Replace the Components] (P16-22) and [11. Disassembly Drawing] (P23-25).

Trouble		Possible cause	Countermeasure	Page for reference
Category	Failure			
Air leakage	Air leaks from the bonnet exhaust port.	7. Back pressure exceeding the set pressure is applied to the downstream.	Revise the air circuit so that back pressure does not exceed the set pressure.	—
	Air leaks from between the bonnet and the body.	1. Loosened bonnet screws.	Fasten the bonnet.	P16
		2. Diaphragm is damaged.	Replace the diaphragm assembly.	P16
Backward flow	Air does not flow backwards.	1. Product without backflow function is used.	Check the product number if backflow function is equipped.	P8
		2. Foreign materials caught in the sliding part of check valve, leading to malfunction; or the check valve is fixed in a closed position.	Replace the check valve assembly.	P20

Note) Fluorine grease is recommended when applying additional grease.

10. How to Replace the Components



Warning

Before replacement, make sure that no pressure remains in the equipment.

Also, make sure to loosen the knob of the regulator so that the set pressure is zero.

After replacement, confirm that the product satisfies specific functions and no external leakage occurs before operating it.

10-1. Diaphragm Assembly Replacement

Applicable model	Work category	Procedure	Tool	Criteria							
AR20 AR30 AR40 AR50 AR60	Disassembly	1) Loosen the knob completely before disassembly.	-	-							
		2) Remove the 4 screws and remove the bonnet.	AR20/ AR30/ AR40 Phillips screwdriver AR50/ AR60 Hexagon wrench Nominal size: 5	-							
		3) Remove the pressure regulating screw assembly, pressure regulating spring, and diaphragm assembly in that order.	-	-							
	Assembly	4) Assemble the diaphragm assembly, pressure regulating spring, and then pressure regulating screw assembly.	-	Direction of diaphragm assembly and pressure regulating screw assembly							
		5) Assemble the bonnet to the body. While the convex side of the bonnet is facing the IN side, mount it onto the body. Then tighten the 4 mounting screws temporarily, before tightening them diagonally and evenly to fix the bonnet.	AR20/ AR30/ AR40 Phillips screwdriver AR50/ AR60 Hexagon wrench Nominal size: 5	<table border="1"> <thead> <tr> <th colspan="2">Tightening torque</th> </tr> </thead> <tbody> <tr> <td>AR20</td> <td rowspan="3">2.35+/-0.3 N m</td> </tr> <tr> <td>AR30</td> </tr> <tr> <td>AR40</td> </tr> <tr> <td>AR50</td> <td rowspan="2">3.5 +/-0.3 N m</td> </tr> <tr> <td>AR60</td> </tr> </tbody> </table>	Tightening torque		AR20	2.35+/-0.3 N m	AR30	AR40	AR50
Tightening torque											
AR20	2.35+/-0.3 N m										
AR30											
AR40											
AR50	3.5 +/-0.3 N m										
AR60											

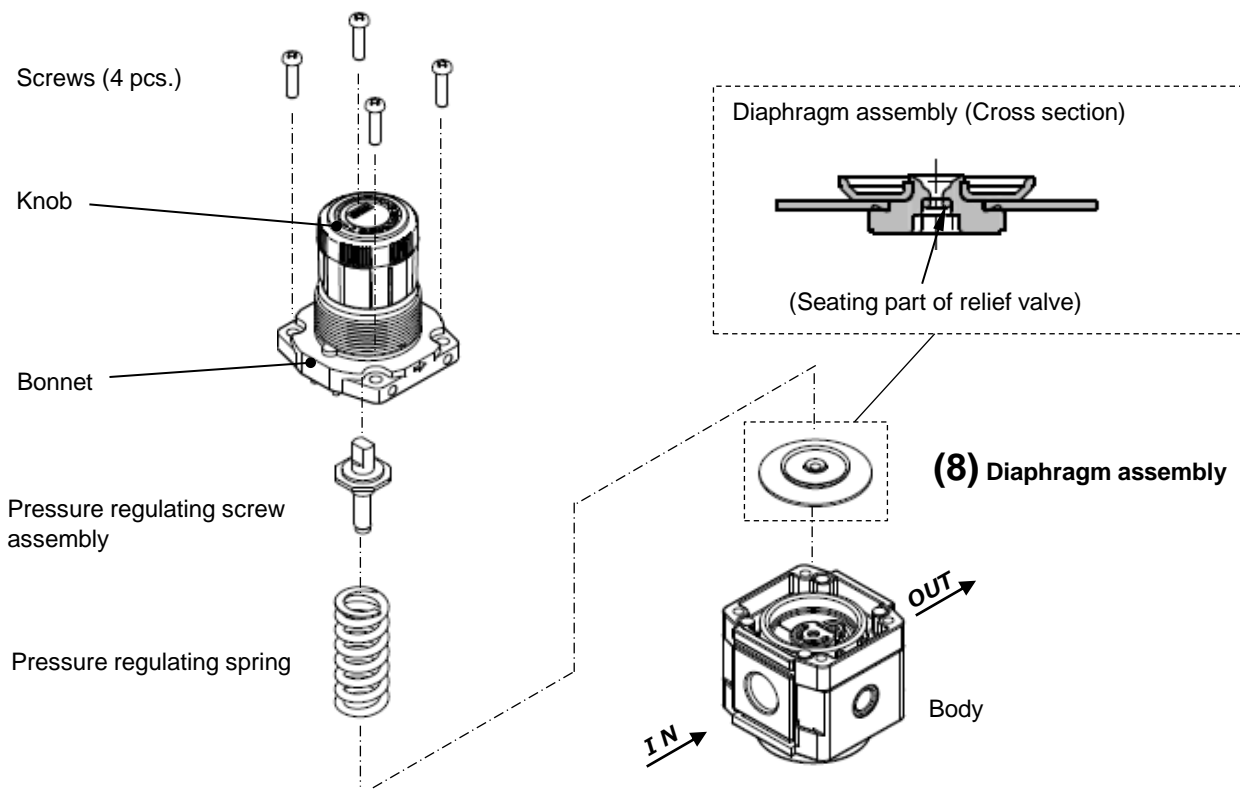

10-2. Valve Guide Assembly and Valve Assembly Replacement

Applicable model	Work category	Procedure	Tool	Criteria
AR20 AR30 AR40 AR50 AR60	Disassembly	1) Remove the cap. Insert a precision screwdriver (-) between the body and cap to lift the cap.	Precision screwdriver (-)	—
		2) Remove the cover. Insert round pliers into the small holes of the cover and rotate 45 degree to the left or right, then lift the cover to remove.	Round pliers Nominal: 125	—
		3) Remove the valve guide assembly. Remove it while lifting the circumferential part with a precision screwdriver.	Precision screwdriver (-)	—
		4) Remove the valve spring.	—	—
		5) Remove the valve assembly.	—	—
	Assembly	6) After replacing the removed components with new components, place them into the regulator. Assemble the components in reverse order to the removal procedure.	—	(See below for the mounting direction of the components.)

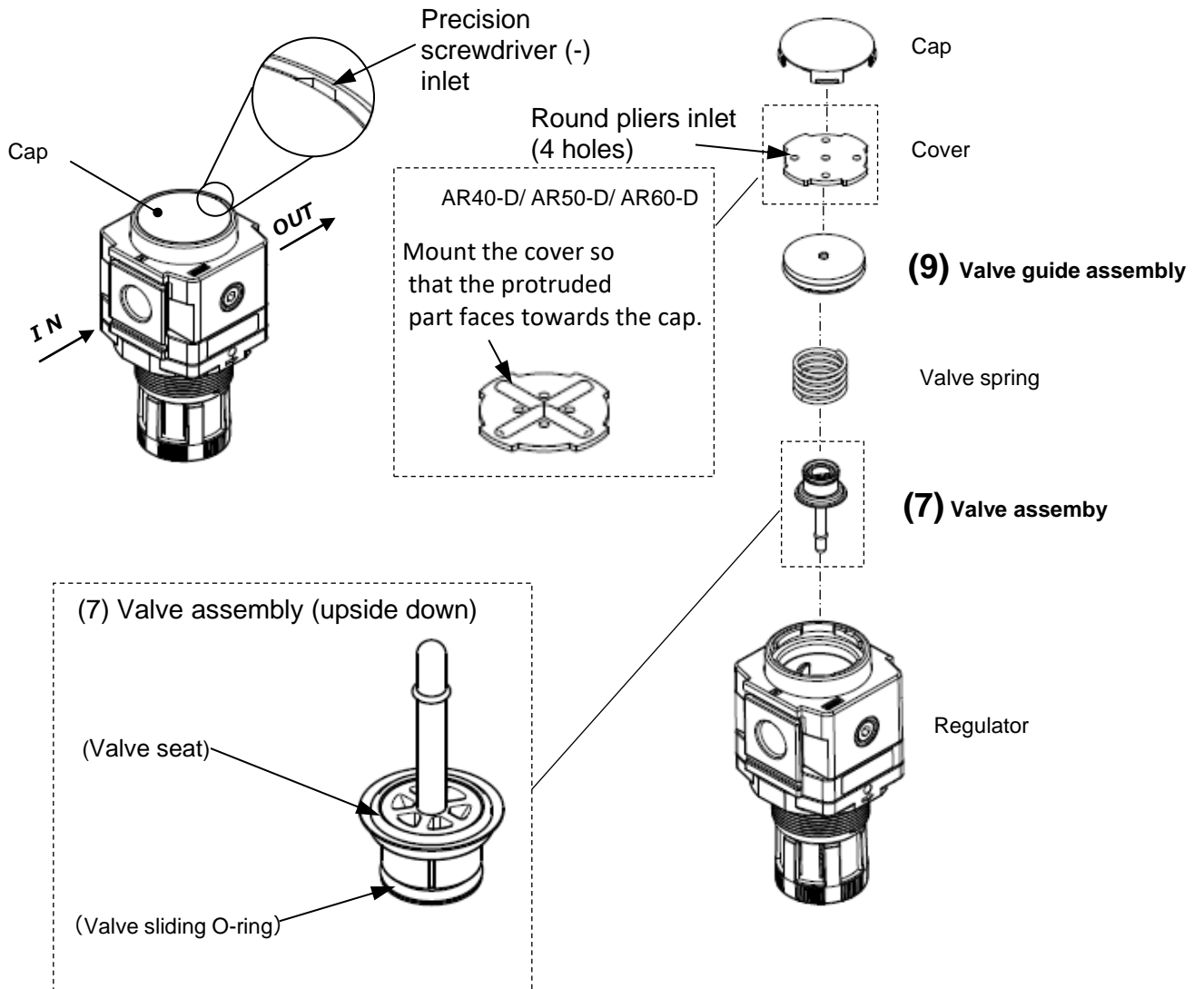

10-3. Square Embedded Type Pressure Gauge Replacement

Applicable model	Work category	Procedure	Tool	Criteria
AR20 AR20K AR30 AR30K AR40 AR40K AR50 AR50K AR60 AR60K	Disassembly	1) Remove the pressure gauge cover. Rotate the pressure gauge cover 15 degrees in the arrow direction (counterclockwise) and pull it out.	-	-
		2) Remove the pressure gauge. Remove the 2 mounting screws and remove the pressure gauge.	Phillips screwdriver	-
	Assembly	3) Confirm that the O-ring is mounted onto the pressure gauge. When the O-ring comes out or is left on the regulator, mount the O-ring to the pressure gauge correctly.	-	Presence of the O-ring
		4) Mount the pressure gauge. Mount the pressure gauge to the regulator with the mounting screws and tighten the screws referring to the tightening torque specified in the right column.	Phillips screwdriver	Tightening torque: 0.85+/-0.05 N m
		5) Mount the pressure gauge cover. Set the pressure gauge cover with its arrow on the lower right corner. Mate the 2 fingers of the pressure gauge cover with the 2 finger slits of the pressure gauge, and rotate the pressure gauge cover 15 degrees to the opposite direction of the arrow (clockwise).	-	-

Note) Applicable to the product with square embedded type pressure gauge (E).

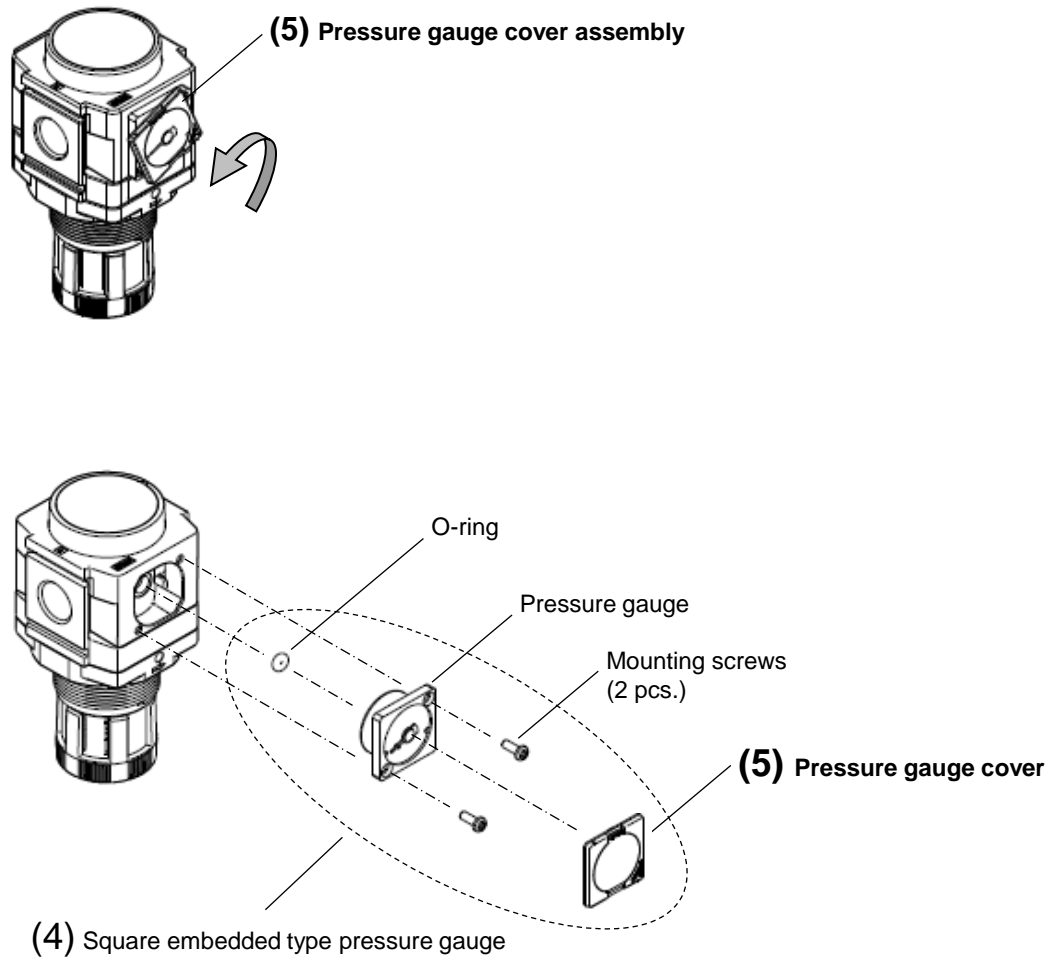

10-4. Blanking Plate Assembly Replacement

Applicable model	Work category	Procedure	Tool	Criteria
AR20 AR30 AR40 AR50 AR60	Disassembly	1) Remove the blanking plate. Remove the 2 mounting screws and remove the blanking plate.	Phillips screwdriver	—
	Assembly	2) Confirm that the O-ring is mounted onto the blanking plate. When the O-ring comes out or is left on the regulator, mount the O-ring to the blanking plate correctly.	—	Presence of the O-ring
		3) Mount the blanking plate. Mount the blanking plate to the product with the mounting screws and tighten the screws referring to the tightening torque specified in the right column.	Phillips screwdriver	Tightening torque: 0.6+/-0.05 N m

Note) Applicable to the product with square embedded type pressure gauge (E) or digital pressure switch (E1 to E4). Not applicable to the product with backflow function.

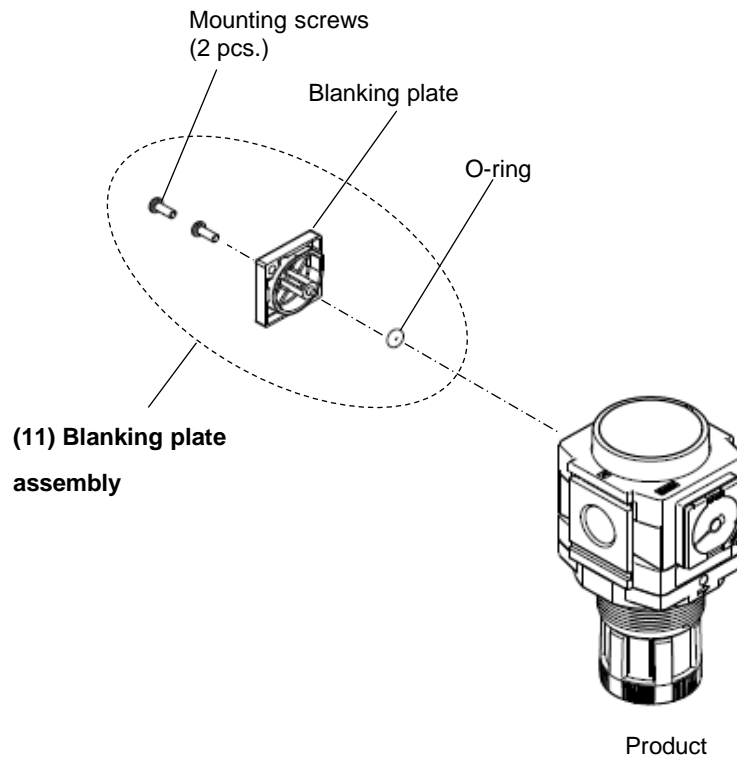

10-5. Check Valve Assembly Replacement

Applicable model	Work category	Procedure	Tool	Criteria
AR20K AR30K AR40K AR50K AR60K	Disassembly	1) Remove the check valve cover. Remove the 2 mounting screws and the check valve cover.	Phillips screwdriver	—
		2) Remove the check valve assembly. Remove the check valve assembly by pulling it toward the operator.		
	Assembly	3) Confirm that the O-ring is mounted onto the check valve assembly. When the O-ring comes out or is left on the regulator, mount the O-ring to the check valve assembly correctly.	—	Presence of the O-ring
		4) Mount the check valve cover. Mount the check valve cover to the product with the mounting screws and tighten the screws referring to the tightening torque specified in the right column.	Phillips screwdriver	Tightening torque: 0.6+/-0.05 N m

Note) Applicable to the product with backflow function.

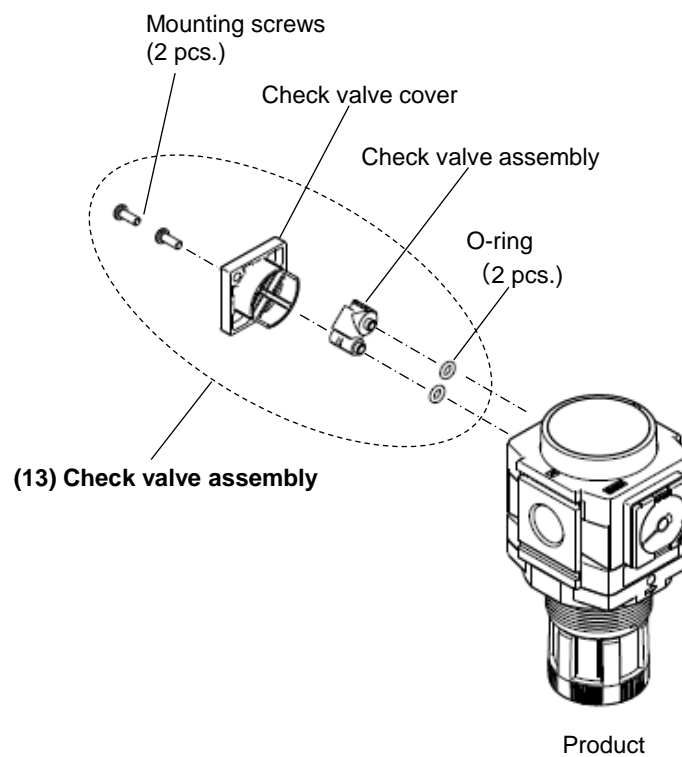

10-6. Plug Assembly Replacement

Applicable model	Work category	Procedure	Tool	Criteria
AR20 AR20K AR30 AR30K AR40 AR40K	Disassembly	1) Remove the plug assembly.	Hexagon wrench (Nominal size: 4)	—
AR50 AR50K AR60 AR60K	Assembly	2) Assemble the plug assembly.	Hexagon wrench (Nominal size: 4)	Tightening torque: 0.6+/-0.05 N m

Note) Applicable to the product without pressure gauge.

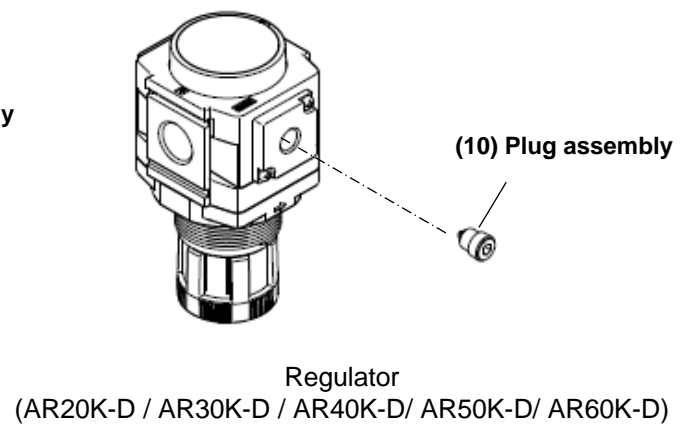
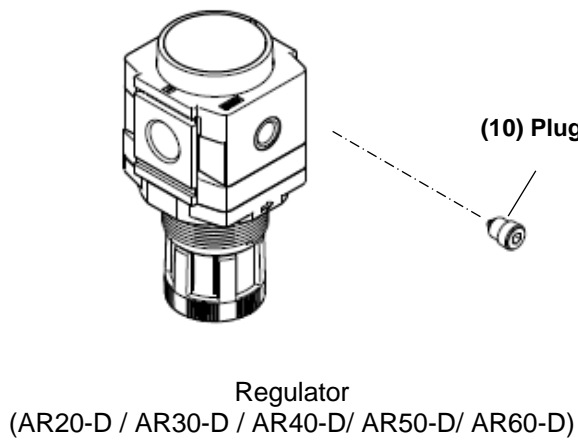

10-7. Plug Assembly Replacement

Applicable model	Work category	Procedure	Tool	Criteria
AR20K AR30K AR40K AR50K AR60K	Disassembly	1) Remove the plug assembly. Remove the 2 mounting screws and remove the plug assembly.	Phillips screwdriver	—
	Assembly	2) Confirm that the O-ring is mounted onto the plug assembly. When the O-ring comes out or is left on the regulator, mount the O-ring to the plug assembly correctly.	—	Presence of the O-ring
		3) Assemble the plug assembly. Assemble the plug assembly to the product with the mounting screws and tighten the screws referring to the tightening torque specified in the right column.	Phillips screwdriver	Tightening torque: 0.6+/-0.05 N m

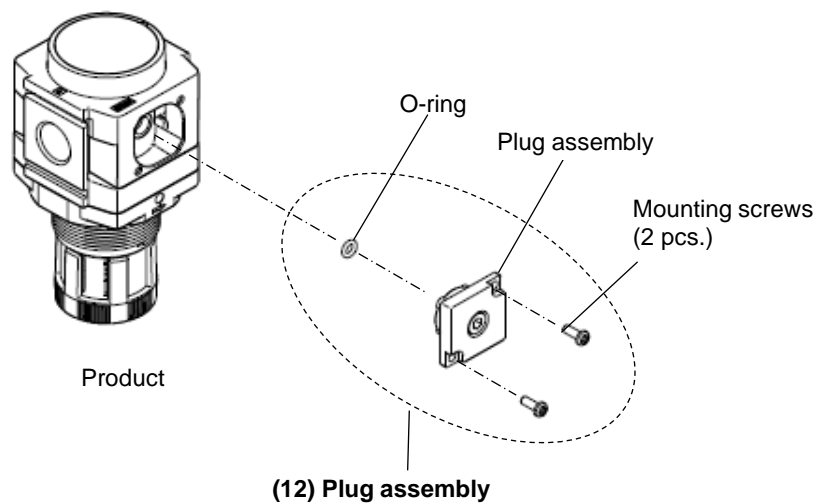

11. Disassembly Drawing

11-1. AR20-D/ AR30-D/ AR40-D/ AR50-D/ AR60-D

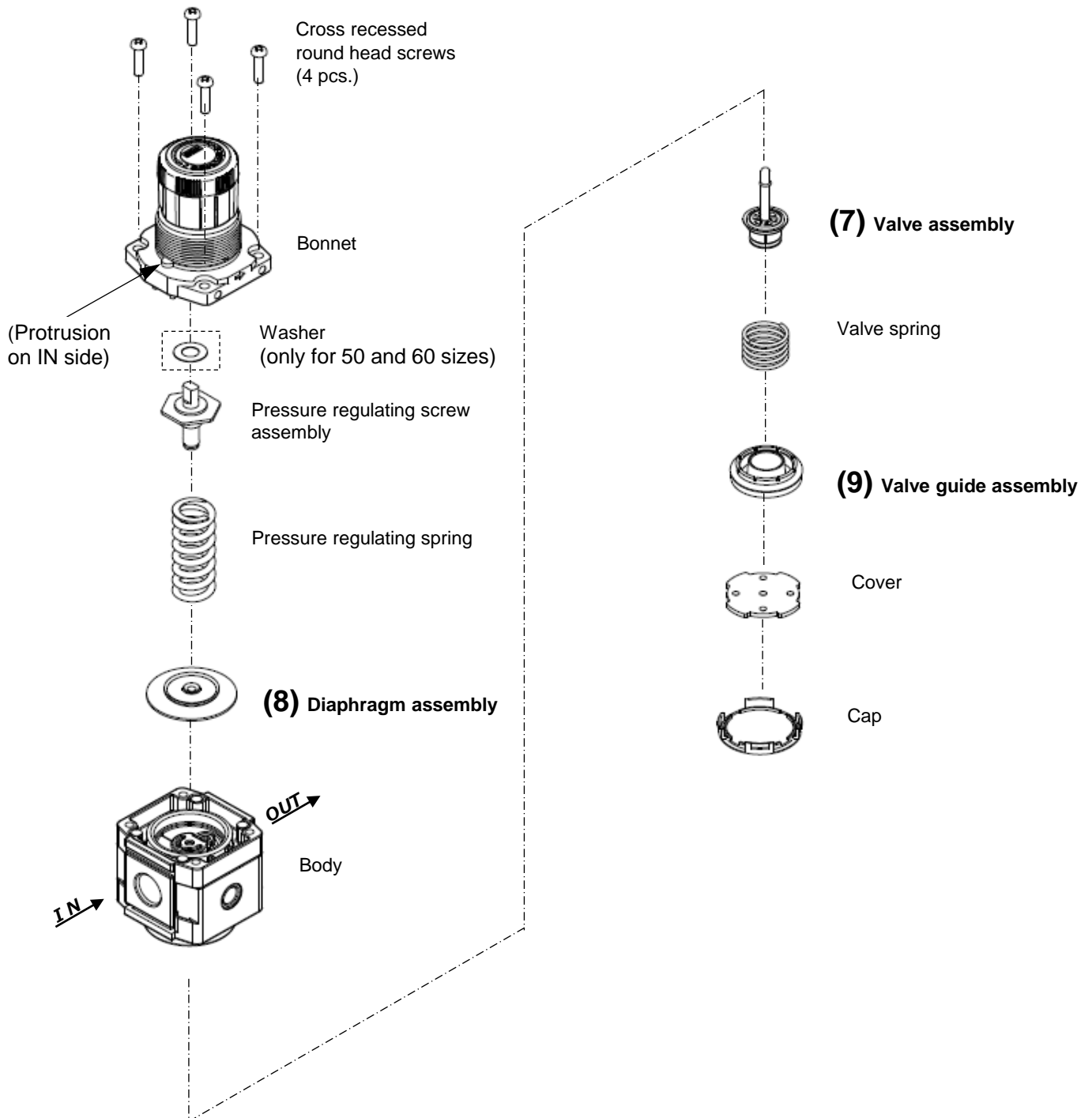

11-2. Disassembly Drawing of the Pressure Gauge Port
 [Applicable model: without pressure gauge / with pressure gauge (round type)]

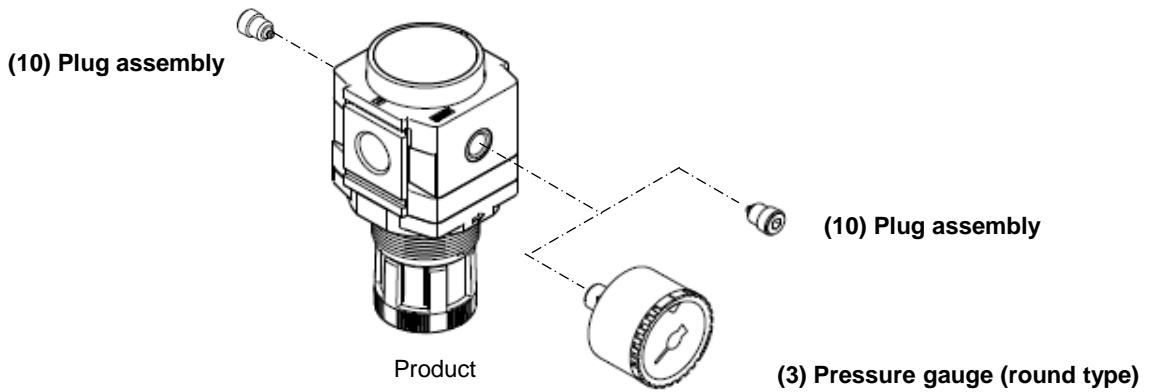

11-3. Disassembly Drawing of the Pressure Gauge Port
 [Applicable model: with square embedded type pressure gauge / with digital pressure switch]

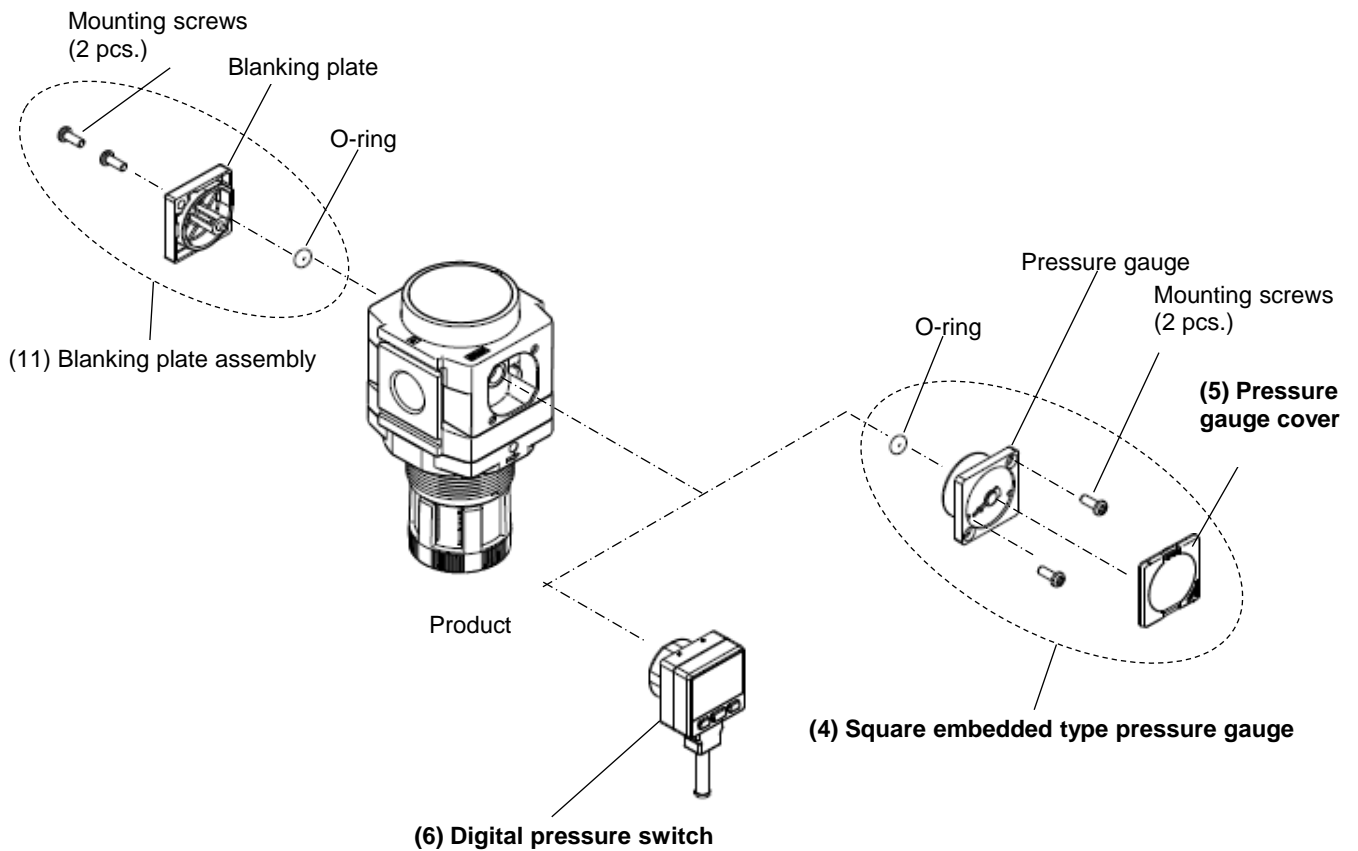

Note) Refer to the operation manual included in the product with digital pressure switch.

- When the pressure gauge or the digital pressure switch is mounted on the back of the product, swap all parts for the front and back.
- When swapping (4) Square embedded type pressure gauge and (6) Digital pressure switch, tighten them with $0.85 \pm 0.05 \text{ N} \cdot \text{m}$. Tighten others with $0.6 \pm 0.05 \text{ N} \cdot \text{m}$.

11-4. Disassembly Drawing of the Pressure Gauge Port
 [Applicable model: with backflow function]

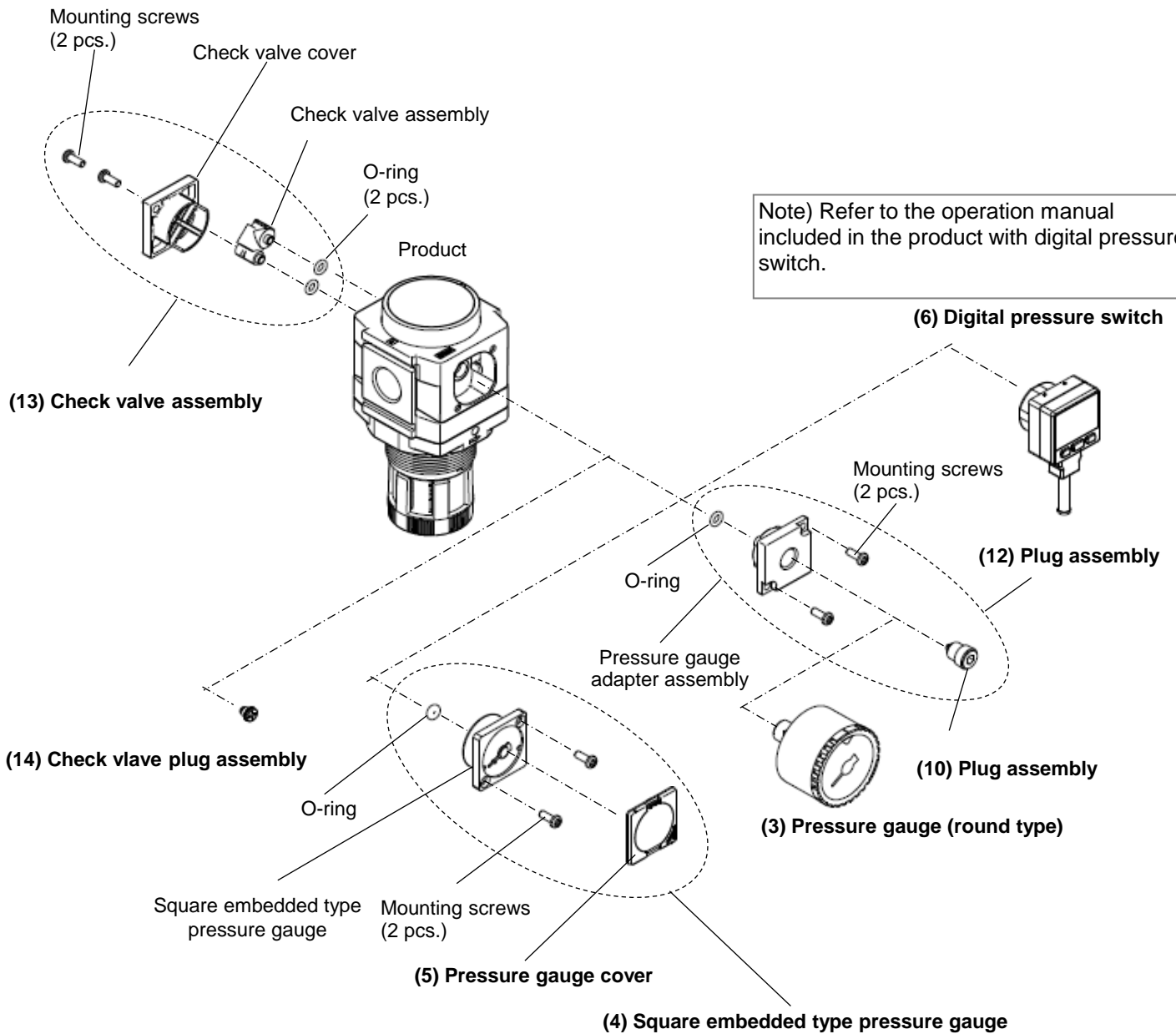

- When the pressure gauge or the digital pressure switch is mounted on the back of the product, swap all parts for the front and back.
- When swapping (4) Square embedded type pressure gauge and (6) Digital pressure switch, tighten them with $0.85 \pm 0.05 \text{ N} \cdot \text{m}$. Tighten others with $0.6 \pm 0.05 \text{ N} \cdot \text{m}$.

12. Dimensions

12-1. Standard (with round type pressure gauge)

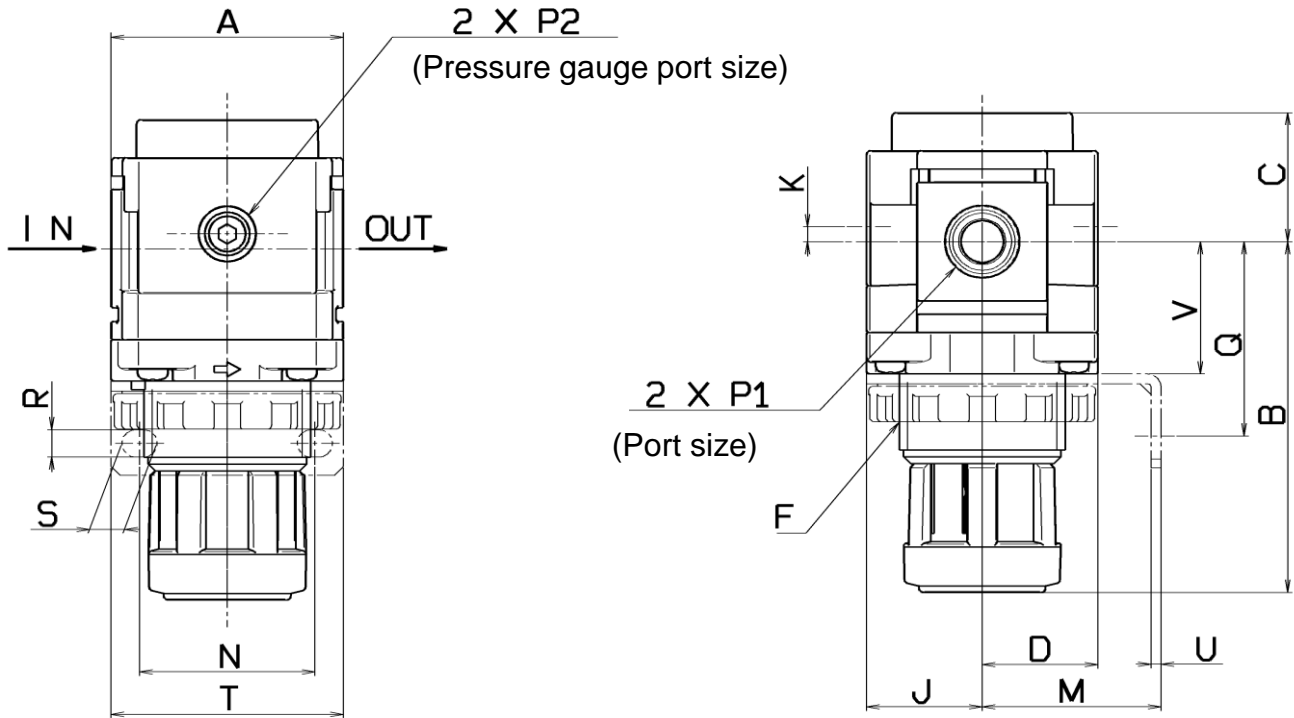

Panel mounting dimensions

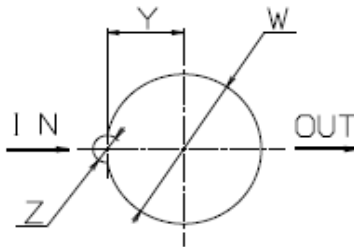
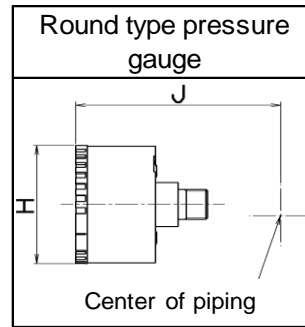

Plate thickness
 AR20/30-D: Max.3.5
 AR40-D: Max.5



Dimensions

Model	Standard specifications									Optional specifications					
										Round type pressure gauge		Round type pressure gauge (Semi-standard: Z)		Round type pressure gauge (with color zone)	
	P ₁	P ₂	A	B	C	D	F	J	K	H	J	H	J	H	J
AR20-D	1/8, 1/4	1/8	40	66.8	26.5	21	M28×1	21	2	Φ37.5	57.5	Φ37.5	58.5	Φ37.5	58.5
AR30-D	1/4, 3/8	1/8	53	86.5	30.5	26.5	M38×1.5	26.5	3.5	Φ37.5	63	Φ37.5	64	Φ37.5	64
AR40-D	1/4, 3/8, 1/2	1/8	70	91.5	35.5	35.5	M42×1.5	35.5	0	Φ42.5	73	Φ42.5	73	Φ42.5	73
AR40-06-D	3/4	1/8	75	93	35.5	35.5	M42×1.5	35.5	0	Φ42.5	73	Φ42.5	73	Φ42.5	73
AR50-D	3/4, 1	1/8	90	125	43	45	M62×1.5	45	0	Φ42.5	82.5	Φ42.5	82.5	Φ42.5	82.5
AR60-D	1	1/8	95	155	45	45	M62×1.5	45	0	Φ42.5	82.5	Φ42.5	82.5	Φ42.5	82.5

Model	Optional specifications										
	Bracket mount							Panel mount			
	M	N	Q	R	S	T	U	V	W	Y	Z
AR20-D	30	34	43.9	5.4	15.4	55	2.3	24.7	28.5	14	6
AR30-D	41	40	46	6.5	8	53	2.3	31.3	38.5	19	7
AR40-D	50	54	54	8.5	10.5	70	2.3	35.5	42.5	21	7
AR40-06-D	50	54	55.5	8.5	10.5	70	2.3	37	42.5	21	7
AR50-D	70	75	66	11	22	113	3.2	-	-	-	-
AR60-D	70	75	66	11	22	113	3.2	-	-	-	-

The dimension of B is the length when the regulator knob is unlocked.

12-2. Standard
(with square embedded type pressure gauge or digital pressure switch)

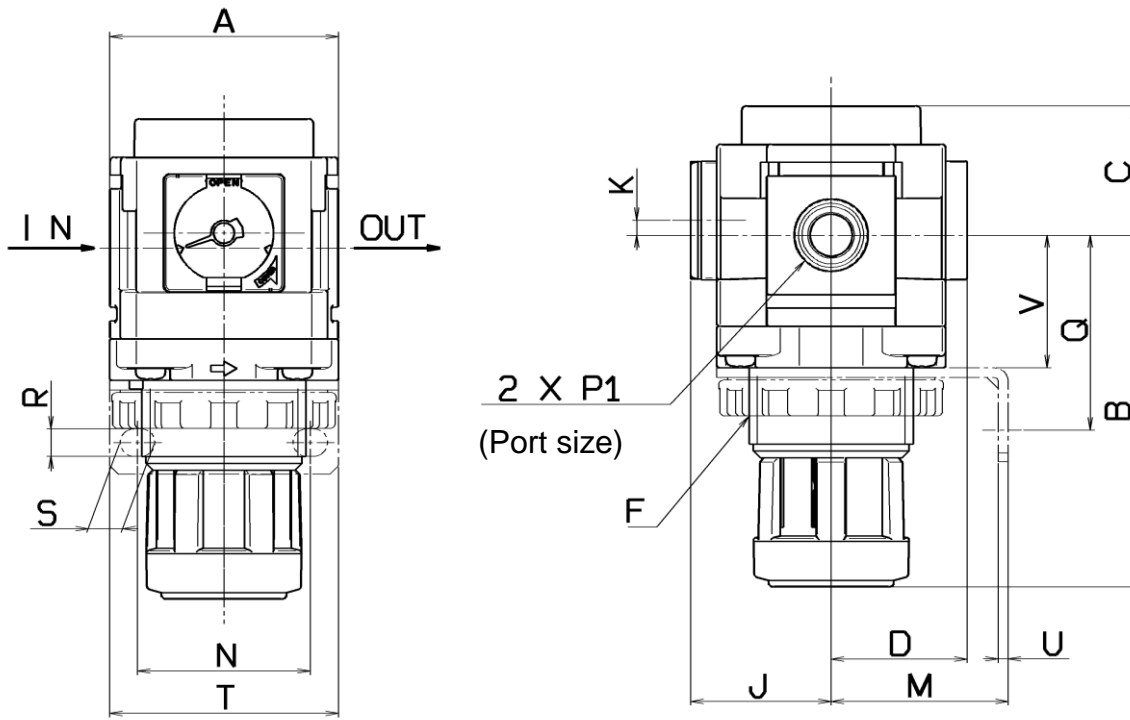

Panel mounting dimensions

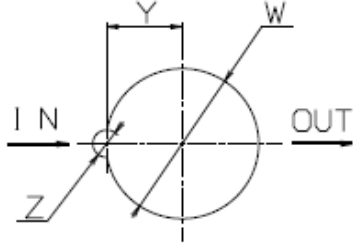

Plate thickness
AR20/AR30-D: Max.3.5
AR40-D: Max.5

Square embedded type pressure gauge	Digital pressure switch
 Center of piping	 Center of piping

Dimensions

Model	Standard specifications							Optional specifications			
								square embedded type pressure gauge		Digital pressure switch	
	P ₁	A	B	C	D	F	K	H	J	H	J
AR20-D	1/8, 1/4	40	66.8	26.5	26	M28×1	2	□28	27	□27.8	37.5
AR30-D	1/4, 3/8	53	86.5	30.5	31.5	M38×1.5	3.5	□28	32.5	□27.8	43
AR40-D	1/4, 3/8, 1/2	70	91.5	35.5	40.5	M42×1.5	0	□28	41.5	□27.8	52
AR40-06-D	3/4	75	93	35.5	40.5	M42×1.5	0	□28	41.5	□27.8	52
AR50-D	3/4, 1	90	125	43	45	M62×1.5	0	□28	51	□27.8	61.5
AR60-D	1	95	155	45	50	M62×1.5	0	□28	51	□27.8	61.5

Model	Optional specifications										
	Bracket mount							Panel mount			
	M	N	Q	R	S	T	U	V	W	Y	Z
AR20-D	30	34	43.9	5.4	15.4	55	2.3	24.7	28.5	14	6
AR30-D	41	40	46	6.5	8	53	2.3	31.3	38.5	19	7
AR40-D	50	54	54	8.5	10.5	70	2.3	35.5	42.5	21	7
AR40-06-D	50	54	55.5	8.5	10.5	70	2.3	37	42.5	21	7
AR50-D	70	75	66	11	22	113	3.2	-	-	-	-
AR60-D	70	75	66	11	22	113	3.2	-	-	-	-

The dimension of B is the length when the regulator knob is unlocked.

12-3. With backflow function

(with round type pressure gauge, square embedded type pressure gauge or digital pressure switch)

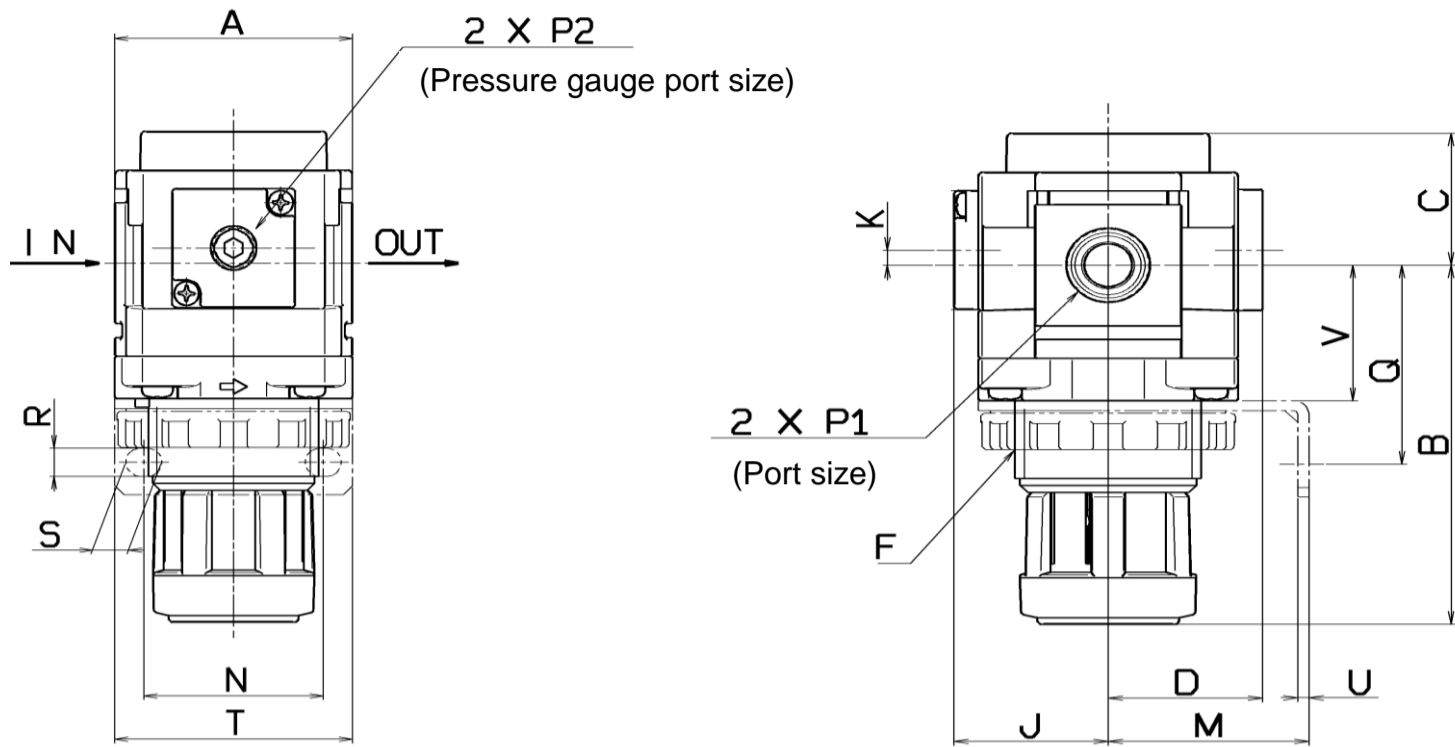

Panel mounting dimensions

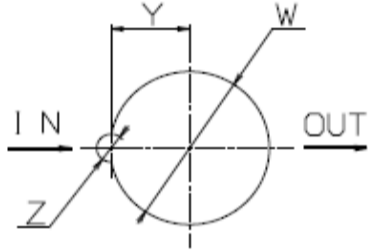

Panel thickness
 AR20K/AR30K-D: Max.3.5
 AR40K-D: Max.5

Round type pressure gauge	Square embedded type pressure gauge	Digital pressure switch

Dimensions

Model	Standard specifications									Optional specifications									
										Round type pressure gauge		Round type pressure gauge (Semi-standard: Z)		Round type pressure gauge (with color zone)		square embedded type pressure gauge		Digital pressure switch	
	P ₁	P ₂	A	B	C	D	F	J	K	H	J	H	J	H	J	H	J	H	J
AR20K-D	1/8, 1/4	1/8	40	66.8	26.5	26	M28×1	26	2	Φ37.5	62.5	Φ37.5	63.5	Φ37.5	63.5	□28	27	□27.8	37.5
AR30K-D	1/4, 3/8	1/8	53	86.5	30.5	31.5	M38×1.5	31.5	3.5	Φ37.5	68	Φ37.5	69	Φ37.5	69	□28	32.5	□27.8	43
AR40K-D	1/4, 3/8, 1/2	1/8	70	91.5	35.5	40.5	M42×1.5	40.5	0	Φ42.5	78	Φ42.5	78	Φ42.5	78	□28	41.5	□27.8	52
AR40K-06-D	3/4	1/8	75	93	35.5	40.5	M42×1.5	40.5	0	Φ42.5	78	Φ42.5	78	Φ42.5	78	□28	41.5	□27.8	52
AR50K-D	3/4, 1	1/8	90	125	43	50	M62×1.5	50	0	Φ42.5	87.5	Φ42.5	87.5	Φ42.5	87.5	□28	51	□27.8	61.5
AR60K-D	1	1/8	95	155	45	50	M62×1.5	50	0	Φ42.5	87.5	Φ42.5	87.5	Φ42.5	87.5	□28	51	□27.8	61.5

Model	Optional specifications										
	Bracket mount						Panel mount				
	M	N	Q	R	S	T	U	V	W	Y	Z
AR20K-D	30	34	43.9	5.4	15.4	55	2.3	24.7	28.5	14	6
AR30K-D	41	40	46	6.5	8	53	2.3	31.3	38.5	19	7
AR40K-D	50	54	54	8.5	10.5	70	2.3	35.5	42.5	21	7
AR40K-06-D	50	54	55.5	8.5	10.5	70	2.3	37	42.5	21	7
AR50K-D	70	75	66	11	22	113	3.2	-	-	-	-
AR60K-D	70	75	66	11	22	113	3.2	-	-	-	-

The dimension of B is the length when the regulator knob is unlocked.

Revision history

A	40-06,50,60 size added, Corrected. Dec. 2020.
---	--

SMC Corporation

4-14-1, Sotokanda, Chiyoda-ku, Tokyo 101-0021 JAPAN

Tel: + 81 3 5207 8249 Fax: +81 3 5298 5362

URL <https://www.smcworld.com>